



Rolling Doors

**COUNTER DOOR FRAME
INSTALLATION INSTRUCTIONS**

FREIGHT DAMAGE INSTRUCTIONS

*****IMPORTANT*****

Immediately upon delivery check condition of materials for visible concealed freight damage incurred in transit.

Under no condition should installation be made without authorization, as neither the carrier nor the Manufacturer will assume responsibility for labor costs involved in replacing damaged material that has been installed.

FOLLOW THE DIRECTIONS BELOW:

CONCEALED DAMAGE:

- (a) Must be inspected by carrier's representative within 15 days from date of delivery.
- (b) Consignee must obtain copy of Inspection Report.
- (c) Material should not be moved from point of delivery to other premises prior to discovery and/or reporting of damage.
- (d) Container and packing should be retained by consignee until inspection is made.

VISIBLE DAMAGE:

- (a) Must be inspected by carrier's representative within 15 days from date of delivery.
- (b) Consignee must obtain copy of Inspection Report.
- (c) Material should not be moved from point of delivery to other premises prior to discovery and/or reporting of damage.
- (d) Container and packing should be retained by consignee until inspection is made.

NOTE: IF DAMAGE IS CERTAIN, GOODS SHOULD NOT BE UNPACKED UNTIL INSPECTION IS MADE. IF DAMAGE IS UNCERTAIN, PACKAGES MAY BE OPENED BUT PACKING MATERIAL MUST BE SAVED UNTIL INSPECTION IS MADE.

INCOMPLETE DELIVERY:

- (a) Should be noted on delivery receipt.
- (b) Acknowledged by driver's signature.
- (c) Start tracing immediately.
- (d) Notify shipper.

RETURNING DAMAGED MATERIAL:

If damaged to the extent that it is necessary to return to the Manufacturer to be repaired, please do as follows:

- (a) Obtain permission to do so from the delivering carrier.
- (b) Route the return shipment via the identical carrier(s) involved in the original shipment.
- (c) Notify the Manufacturer when shipped.

PRE-INSTALLATION INSTRUCTIONS



**ONLY TRAINED DOOR SYSTEMS TECHNICIANS SHOULD
DROP TEST, RESET OR PERFORM MAINTENANCE**



**READ AND FOLLOW THESE INSTRUCTIONS THOROUGHLY - THE COOKSON
COMPANY WILL NOT BE HELD RESPONSIBLE FOR ANY CHARGES INCURRED
THROUGH MISSING PARTS, OPERATION, OR DAMAGE- DUE TO IMPROPERLY
INSTALLED DOOR ASSEMBLIES**

- 1) If you have received more than one door, you will find that all major parts and pieces for any one door are marked with corresponding numbers; therefore, a complete door should be composed of parts bearing the same numbers and letters.

DO NOT INTERCHANGE PARTS FROM ONE DOOR TO ANOTHER!!!

- 2) Before installing the door see that all component markings agree.
- 3) Before attempting installation of the door and, specifically, before leaving the jobsite make certain you have read and adhered to the attached "Safety Check List".
- 4) Should there be any discrepancies in the job conditions or manufactured materials, contact The Cookson Company in writing or by calling 1-800-294-4358 for Western U.S. and Canada or 1-800-390-8590 for Eastern U.S. and Canada. If door was purchased by a Cookson Distributor and sold to another party they should contact the Distributor for Warranty or Repair parts.

SAFETY CHECK LIST

**IN ORDER FOR YOU TO ASSURE YOUR CUSTOMER THAT THIS DOOR HAS BEEN
INSTALLED PROPERLY AND IN A SAFE MANNER, WE ASK THAT YOU CHECK THE
FOLLOWING BEFORE LEAVING THE JOBSITE.**

- 1) Make certain that the proper amount of tension has been applied to the torsion springs, in order to properly counterbalance the weight of the curtain.
- 2) Assure yourself that the tension wheel is securely fastened in place.
- 3) Assure yourself that sprockets or gears requiring keys have the correct keys installed and drive shaft sprockets or gears are retained by cotter pins.
- 4) Recheck the setscrews (One over key - the other located at 45° from key) in each sprocket or gear for tightness.
- 5) Check all fasteners holding guides to building structures.
- 6) Check all fasteners used in assembling door components.
- 7) Instruct owner or his/her representative in the proper method of operating this door.

COUNTER DOOR FRAME FRAME INSTALLATION INSTRUCTIONS

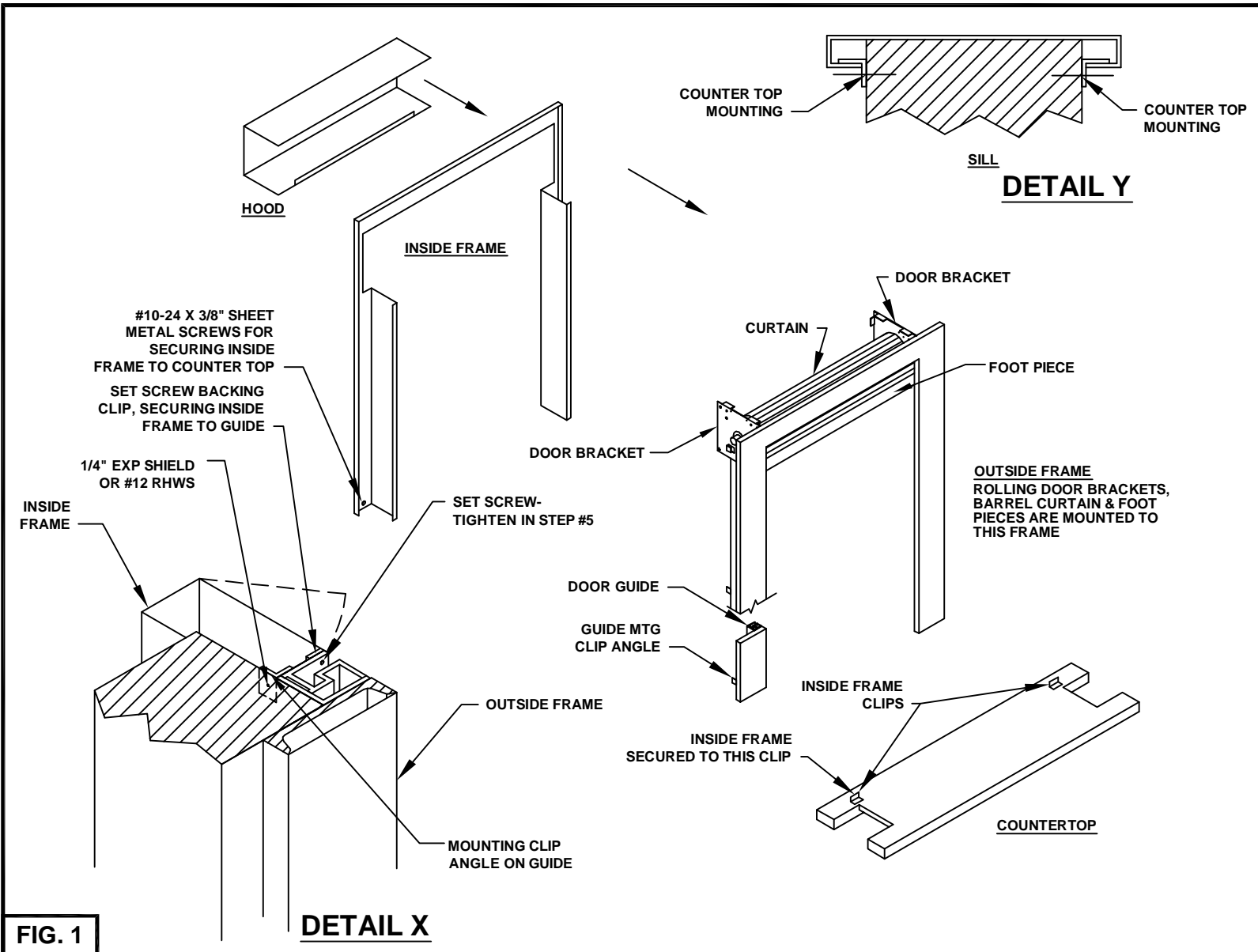

Door and frame are shipped completely assembled (See Note) and must be disassembled into the four (4) following pieces before installation:

- 1- Hood
- 2- Inside Frame
- 3- Outside Frame- Lift up to remove
- 4- Countertop

To remove inside frame, loosen set screw and push out from under clips mounted on guide- See Detail X.

Note: For doors over approx. 40 sq ft, Curtain is shipped separately. Torsion spring tension will have to be adjusted.

FASTENERS

JAMB	FASTENERS	INSTRUCTIONS
WOOD	#12 RHWS	Pre-drill holes with 1/8" drill for mounting guides to jamb with #12 wood screws.
MASONRY	PLASTIC SHIELD WITH #12 RHWS	Drill concrete w/Ø5/16" star drill 1-1/2" deep and insert #12 plastic shields as mfg by Holub.
STEEL	1/4" RHMS	Drill steel jambs with #7 drill and tap hole with 1/4-20 NC tap.

COUNTER DOOR FRAME

FRAME INSTALLATION INSTRUCTIONS

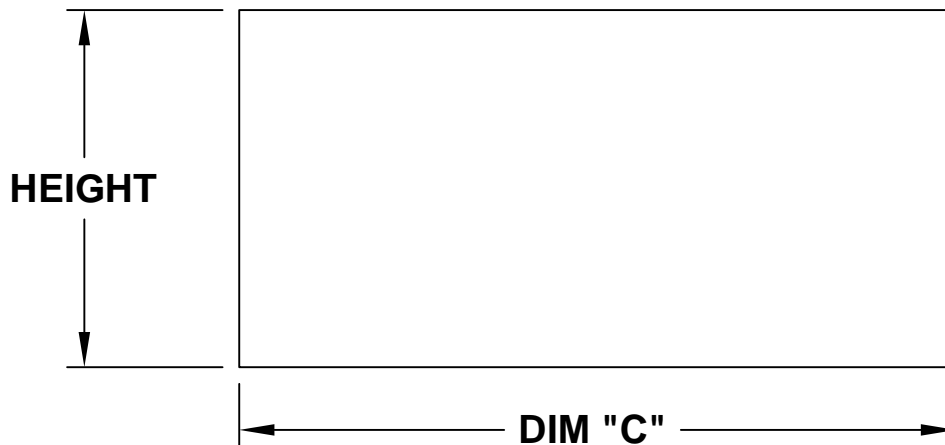

- 1) CHECK OPENING HEIGHT AND WIDTH (DIM "C").
- 2) CHECK SILL TO SEE THAT IT IS LEVEL. NOW PLACE COUNTERTOP ON SILL PER DETAIL "Y".
- 3) PLACE OUTSIDE FRAME ON COUNTERTOP AND TILT INTO POSITION AND SECURE TO JAMB. SEE DETAIL "X".
- 4) NOW SLIDE INSIDE FRAME OVER DOOR BRACKETS AND SLIP FRAME INTO CLIPS MOUNTED ON GUIDES AS SHOWN IN DETAIL "X".
- 4A) FOR DOORS WITHOUT CURTAIN INSTALLED, SEE PAGES 4 & 5 FOR CURTAIN INSTALLATION AND TENSIONING INSTRUCTIONS.
- 5) LOWER CURTAIN TO COUNTERTOP AND MOUNT HOOD IN PLACE.
- 6) TIGHTEN SET SCREWS IN GUIDE GROOVE. MAKE SURE INSIDE FRAME IS FLUSH WITH TIP OF GUIDE AS SHOWN IN DETAIL "X".
- 7) NOW SCREW INSIDE FRAME TO CLIPS ON COUNTERTOP.
- 8) CURTAIN COUNTERBALANCE MECHANISM HAS BEEN COMPLETELY ADJUSTED AND FIELD ADJUSTMENT SHOULD NOT BE NECESSARY, UNLESS CURTAIN IS SHIPPED SEPARATELY.

CURTAIN INSTALLATION INSTRUCTIONS

- 1) With the curtain rolled up (as shipped from the factory) place it in slings below the barrel as shown below in Fig. 2. The slings may be made from soft cotton clothesline or other material that will not scratch the anodized finish.

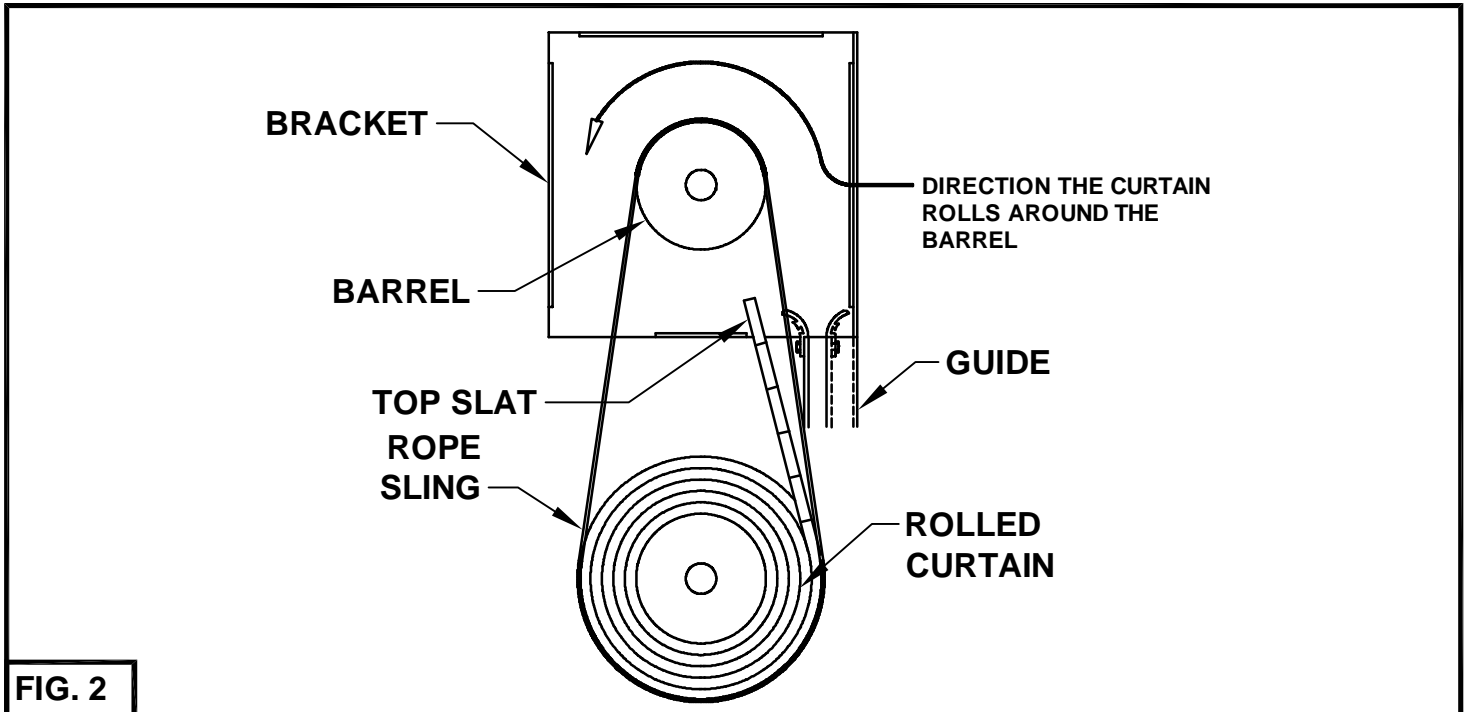

IMPORTANT: ALL TENSION WHEELS MUST BE FREE TO ROTATE DURING THE INSTALLATION OF THE CURTAIN. BACK OUT THE HEX HEAD BOLT ON THE INSIDE TENSION WHEEL PAWL SO THAT THE PAWL WILL RACHET. FAILURE TO DO THIS WILL BACKWIND THE SPRING AND CAUSE DAMAGE. Pull the top slat around the barrel and line up the slots in the slat with the holes in the barrel. The clearance between the end of the curtain and the brackets must be the same on each end. Bolt the curtain to the barrel with the screws provided.

CAUTION: THE USE OF LONGER SCREWS THAN PROVIDED WILL INTERFERE WITH AND DAMAGE THE OPERATION OF THE TORSION SPRING IN THE BARREL (SEE PAGE 5).

- If hoops are used: Line up the hoops according to the punched holes in the top slat, being sure that the edges of the curtain are equidistant from each bracket, and so that the curtain is straight on the bracket. Bolt curtain to the hoops.
- 2) Now roll the curtain around the barrel with the rope slings in place. When the curtain is completely wrapped around the barrel, feed the bottom bar into the guide grooves. Slowly lower the curtain all the way down so that the opening is now closed and reinstall the stops onto the guides.

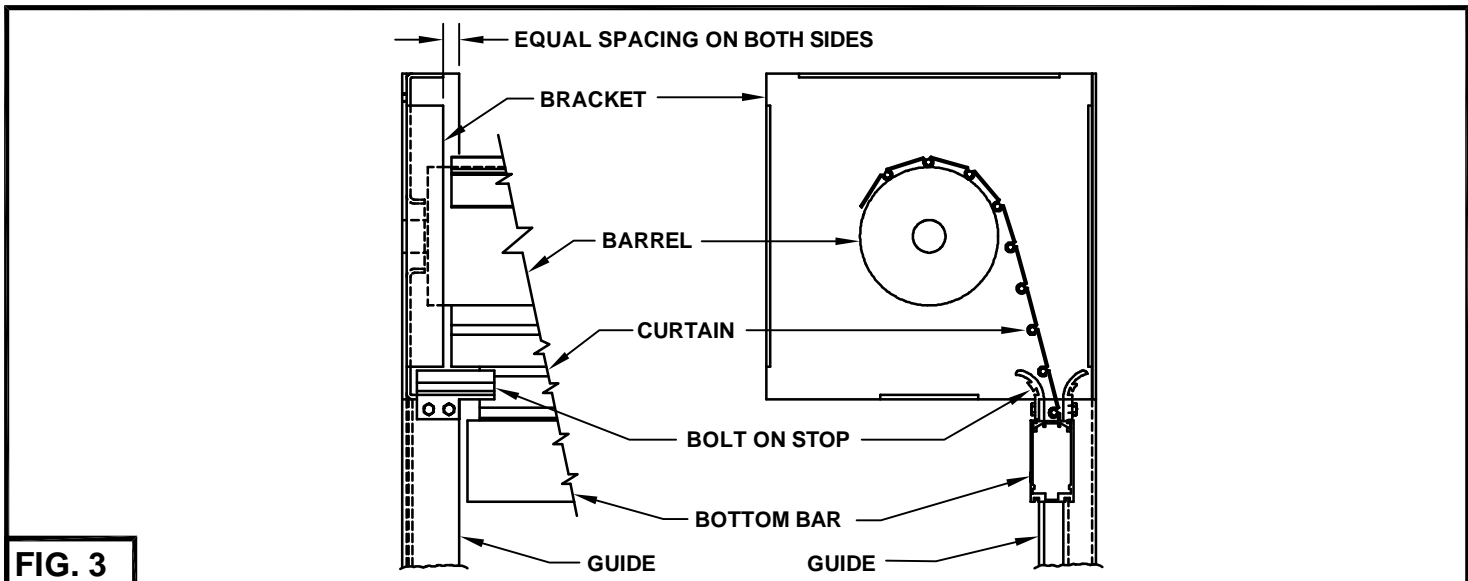

COUNTERBALANCING INSTALLATION

Inside Tension Wheel:

- 1) With the barrel and the curtain set in the proper location, make sure that the tension wheel set screws are tightened to the barrel shaft. Apply tension to the counterbalancing spring with the door in the closed position as follows: Engage an 8" adjustable wrench onto the squared shaft and rotate the wheel in the direction that the barrel must rotate to roll up the curtain onto the barrel. See the Installation Information Sheet for the range that the tension should be set at. Be sure before removing the wrench each time that the pawl is engaged in the tension wheel. After the tension is properly set, lock down the tension pawl with the HHMB in the pawl.

Outside Tension Wheel:

- 2) Install the outside tension wheel onto the coped shaft. Apply tension to the counterbalancing spring with the door in the open position as follows: See the Installation Information Sheet for the proper amount of tension to apply. Apply tension to the counterbalancing spring in the same direction the curtain rolls onto the barrel. Install the locking bolt after the tension has been applied. The operation of the door should be such that the door will stay at the head and at the floor.

CAUTION: UNDER NO CIRCUMSTANCES SHOULD MORE THAN ONE FULL TURN BE ADDED OVER THAT WHICH IS REQUIRED TO HOLD THE CURTAIN'S BOTTOM BAR AT THE GUIDE STOPS.

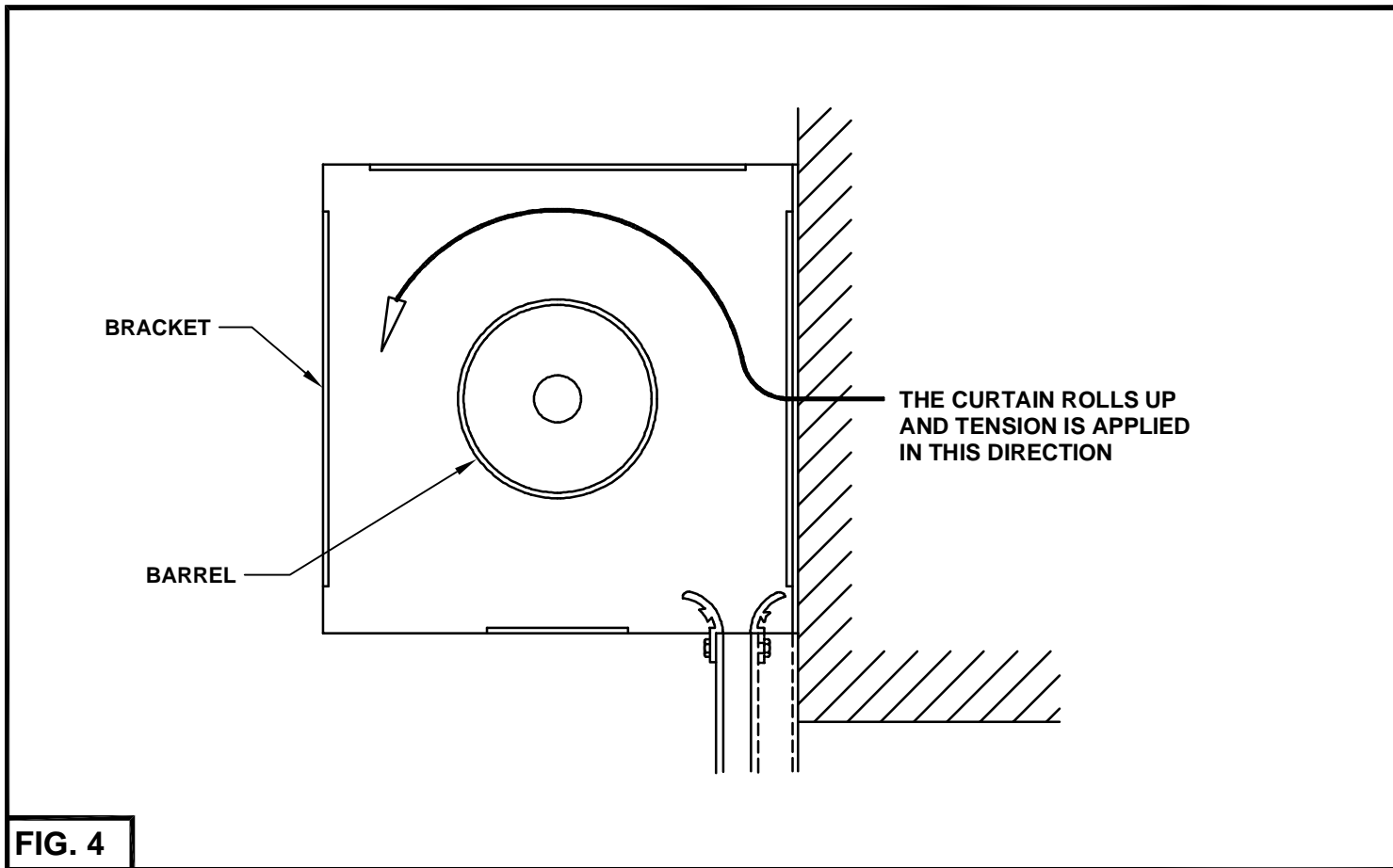

TUBULAR MOTOR OPERATED DRIVE BRACKET DETAIL

RIGHT-HAND MOTOR

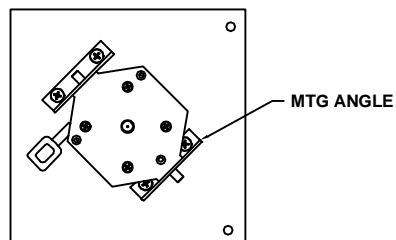
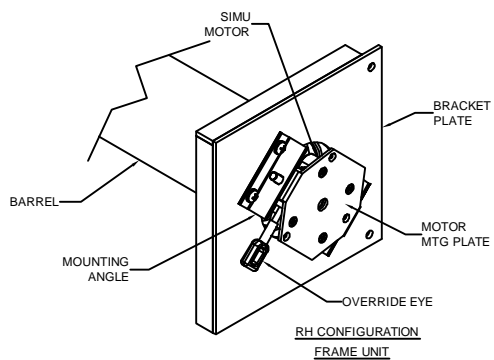

LEFT-HAND MOTOR

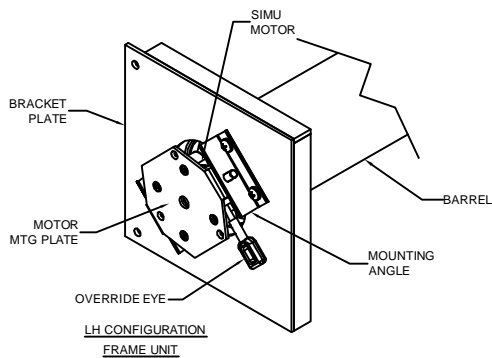
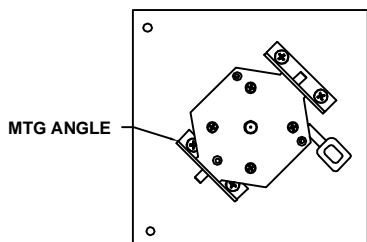

FIG. 5