

## REFERENCED PUBLICATIONS

### NFPA 80

#### Standard for

#### Fire Doors and Other Opening Protectives

#### 2010 Edition

#### Chapter 3 Definitions

#### 3.2 NFPA Official Definitions.

**3.2.1\* Approved.** Acceptable to the authority having jurisdiction.

**3.2.2\* Authority Having Jurisdiction (AHJ).** An organization, office, or individual responsible for enforcing the requirements of a code or standard, or for approving equipment, materials, an installation, or a procedure.

**3.2.3 Labeled.** Equipment or materials to which has been attached a label, symbol, or other identifying mark of an organization that is acceptable to the authority having jurisdiction and concerned with product evaluation, that maintains periodic inspection of production of labeled equipment or materials, and by whose labeling the manufacturer indicates compliance with appropriate standards or performance in a specified manner.

**3.2.4\* Listed.** Equipment, materials, or services included in a list published by an organization that is acceptable to the authority having jurisdiction and concerned with evaluation of products or services, that maintains periodic inspection of production of listed equipment or materials or periodic evaluation of services, and whose listing states that either the equipment, material, or service meets appropriate designated standards or has been tested and found suitable for a specified purpose.

**3.2.5 Shall.** Indicates a mandatory requirement.

**3.2.6 Should.** Indicates a recommendation or that which is advised but not required.

**3.3.11 Barrel.** A cylindrical horizontal member at the head of the opening that supports the door curtain of a rolling steel door and contains the counterbalance springs.

**3.3.15 Bottom Bar (Rolling Steel Door).** A reinforcing member at the lower edge of the door curtain assembly.

**3.3.25 Closed Position (Rolling Steel Fire Door).** A position of the door curtain with the underside of the bottom bar, including a compressible seal or sensing edge, if provided, in contact with the sill along the entire width of the opening.

**3.3.31 Counterbalancing.** A method by which the hanging weight of the door is balanced by helical torsion springs or weights.

**3.3.33 Crush Plates.** Bearing plates provided where doors are mounted on concrete masonry wall units with hollow cells to accommodate through-wall bolts to prevent crushing of the hollow concrete masonry unit.

**3.3.34 Curtain (Rolling Steel Fire Door).** Interlocking curtain slats assembled together.

**3.3.35 Curtain Slats.** Formed sheet steel members that, when interlocked together, form the rolling steel door curtain.

#### 3.3.37. Door.

**3.3.37.3 Power-Operated Fire Door.** See 3.3.92

**3.3.37.5 Service Counter Fire Door.** See 3.3.104

**3.3.39 Door Holder/Release Device.** A labeled, fail-safe device, controlled by a detection device, used on an automatic closing door to release the door at the time of fire.

**3.3.45 Fail-Safe Device.** A device that will provide its intended function upon loss of power.

**3.3.50 Fire Door Assembly.** Any combination of a fire door, a frame, hardware, and other accessories that together provide a specific degree of fire protection to the opening.

**3.3.63 Fire Shutter.** A fire door assembly used for the protection of a window opening in an exterior wall.

**3.3.65 Flame Baffle.** A hinged piece of sheet metal within the hood that, when released, closes the space between the top of the curtain and the hood of a rolling steel fire door.

**3.3.69 Fusible Link.** For the purposes of this standard, a listed device consisting of pieces of metal held together by low-melting-point solder.

**3.3.71 Governor (Sliding, Vertical, and Rolling Steel Fire Doors).** A device that limits the rate of descent of the door during automatic closure.

**3.3.72 Guide (Rolling Doors).** Vertical assembly in which the curtain travels and that is fastened to the jamb, retaining the edges of the door curtain, and closing the space between the curtain, edges and the jamb.

**3.3.75 Guide Wall Angle (Rolling Steel Doors).** The component of the guide assembly that is fastened to the jamb.

**3.3.79 Hood (Rolling Steel Door).** A sheet metal housing that mounts horizontally between the brackets, serving as an enclosure for the coiled curtain and closing the space between the door coil and the lintel.

**3.3.85 Lintel.** A horizontal member spanning and carrying the load above an opening.

Reprinted with permission from NFPA 80-2010, *Fire Doors and Other Protectives*, Copyright © 2010, National Fire Protection Association, Quincy, MA 02169. This reprinted material is not the complete and official position of the NFPA on the referenced subject, which is represented only by the standard in its entirety.

## DEFINITIONS

**3.3.92 Power-Operated Fire Doors.** Doors that normally are opened and closed electrically or pneumatically.

**3.3.97 Retrofit Operator.** A device labeled as a “retrofit rolling steel fire door operator” intended to replace operator and governor systems (including automatic-closing devices) used on existing listed rolling steel fire doors.

**3.3.99\* Rolling Steel Fire Door.** A fire door assembly consisting of a curtain, a bottom bar, a barrel, brackets, guides, a hood, and an automatic-releasing device.

**3.3.103 Sensing Edge (Rolling Steel Fire Door).** A device added to the underside of the bottom bar of a power-operated rolling steel fire door or fire shutter that stops or reverses the door curtain upon contact with an obstruction when closing under power.

**3.3.104 Service Counter Fire Door.** A labeled assembly consisting of a rolling steel fire door that incorporates a four-sided frame used for the protection of openings in walls where the primary purpose of the opening is for nonpedestrian use, such as counter service for food, a pharmaceutical dispensary, package and baggage transfer, or observation ports.

**3.3.105 Shutter.** A labeled door assembly that is used for the protection of a window opening in an exterior wall. (*See also 3.3.63, Fire Shutter.*)

**3.3.110 Sill (Rolling Steel Fire Door).** The bottom part of an opening onto which the door curtain and bottom bar come to rest when in the closed position.

**3.3.111 Sill (Service Counter Fire Door).** The bottom part of a frame onto which the door curtain and bottom bar come to rest when in the closed position.

**3.3.115 Smoke Detector.** A device that detects visible or invisible particles of combustion. [72, 2010]

**3.3.117 Spring Release Device (Rolling Steel Door).** A device that, when activated, releases part of the spring counterbalancing force and causes the door to close.

### Chapter 5 Care and Maintenance

#### 5.1.1 Application.

**5.1.1.1** This chapter shall cover the care and maintenance of fire doors and fire windows.

**5.1.1.2** The requirements of this chapter shall apply to new and existing installations.

#### 5.1.3 Operability.

**5.1.3.1** Doors, shutters, and windows shall be operable at all times.

**5.1.4 Replacement.** Where it is necessary to replace fire doors, shutters, windows or their frames, glazing materials,

hardware, and closing mechanisms, replacements shall meet the requirements for fire protection and shall be installed as required by this standard for new installations.

#### 5.1.5 Repairs and Field Modifications.

**5.1.5.1** Repairs shall be made, and defects that could interfere with operation shall be corrected without delay.

#### 5.2\* Inspections.

**5.2.1\*** Fire door assemblies shall be inspected and tested not less than annually, and a written record of the inspection shall be signed and kept for inspection by the AHJ.

#### 5.2.3 Functional Testing.

**5.2.3.1** Functional testing of fire door and window assemblies shall be performed by individuals with knowledge and understanding of the operating components of the type of door being subject to testing.

**5.2.3.2** Before testing, a visual inspection shall be performed to identify any damaged or missing parts that can create a hazard during testing or affect operation or resetting.

#### 5.2.5 Horizontally Sliding, Vertically Sliding, and Rolling Doors.

**5.2.5.1** Fire door assemblies shall be visually inspected from both sides to assess the overall condition of door assembly.

**5.2.5.2** The following items shall be verified:

- (1) No open holes or breaks exist in surfaces of either the door or frame.
- (2) Slats, endlocks, bottom bar, guide assembly, curtain entry hood, and flame baffle are correctly installed and intact.
- (3) Glazing, vision light frames, and glazing beads are intact and securely fastened in place, if so equipped.
- (4) Curtain, barrel, and guides are aligned, level, plumb, and true.
- (5) Expansion clearance is maintained in accordance with manufacturer’s listing.
- (6) Drop release arms and weights are not blocked or wedged.
- (7) Mounting and assembly bolts are intact and secured.
- (8) Attachment to jambs are with bolts, expansion anchors, or as otherwise required by the listing.
- (9) Smoke detectors, if equipped, are installed and operational.
- (10) No parts are missing or broken.
- (11) Fusible links, if equipped, are in the location; chain/cable, s-hooks, eyes, and so forth, are in good condition (i.e., no kinked or pinched cable, no twisted or inflexible chain); and links are not painted or coated with dust or grease.
- (12) Auxiliary hardware items that interfere or prohibit operation are not installed on the door or frame.
- (13) No field modifications to the door assembly have been performed that void the label.

**5.2.6** Inspection shall include an operational test for automatic-closing doors and windows to verify that the assembly will close under fire conditions.

Reprinted with permission from NFPA 80-2010, *Fire Doors and Other Protectives*, Copyright © 2010, National Fire Protection Association, Quincy, MA 02169. This reprinted material is not the complete and official position of the NFPA on the referenced subject, which is represented only by the standard in its entirety.

## CARE AND MAINTENANCE

---

**5.2.7** Assembly shall be reset after a successful test.

**5.2.8** Resetting of the release mechanism shall be done in accordance with manufacturer's instructions.

### **5.2.12 Lubrication and Adjustments.**

**5.2.12.1** Guides and bearings shall be kept well lubricated to facilitate operation.

### **5.2.13 Prevention of Door Blockage.**

**5.2.13.1** Door openings and the surrounding areas shall be kept clear of anything that could obstruct or interfere with the free operation of the door.

**5.2.13.3** Blocking or wedging of doors in the open position shall be prohibited.

### **5.2.14 Maintenance of Closing Mechanisms.**

**5.2.14.1** Self-closing devices shall be kept in working condition at all times.

**5.2.14.3** All horizontal or vertical sliding and rolling fire doors shall be inspected and tested annually to check for operation and full closure.

**5.2.14.3.1** Resetting of the automatic-closing device shall be done in accordance with the manufacturer's instructions.

**5.2.14.3.2** A written record shall be maintained and shall be made available to the AHJ.

**5.2.14.3.3** When conducting the annual test for operation and full closure, rolling steel fire doors shall be drop tested twice.

**5.2.14.3.4** The first test shall be to check for operation and full closure.

**5.2.14.3.5** A second test shall be done to verify that the automatic-closing device has been reset correctly.

**5.2.14.4** Fusible links or other heat-actuated devices and release devices shall not be painted.

**5.2.14.5\*** Paint shall be prevented from accumulating on any movable part.

### **5.2.15 Repair of Fire Doors and Windows.**

**5.2.15.3** Where a fire door, frame, or any part of its appurtenances is damaged to the extent that it could impair the door's proper emergency function, the following actions shall be performed:

- (1) The fire door, frame, or any part of its appurtenances shall be repaired with labeled parts obtained from the original manufacturer.
- (2) The door shall be tested to ensure emergency operation and closing upon completion of the repairs.

### **5.3 Retrofit Operators.**

**5.3.1** The operator, governor, and automatic-closing device on rolling steel fire doors shall be permitted to be retrofitted with a labeled retrofit operator under the conditions specified in 5.3.2 through 5.3.5.

**5.3.2** The retrofit operator shall be labeled as such.

**5.3.3** The retrofit operator shall be installed in accordance with its installation instructions and listing.

**5.3.4** The installation shall be acceptable to the AHJ.

**5.3.5** The retrofit operator shall be permitted to be provided by a manufacturer other than the original manufacturer of the rolling steel fire door on which it is retrofitted, provided its listing allows it to be retrofitted on that manufacturer's doors.

## **Chapter 11 Rolling Steel Doors**

### **11.1 Doors.**

**11.1.1 General.** This chapter shall cover the installation of rolling steel fire doors.

#### **11.1.2 Mounting of Doors.**

**11.1.2.1\*** The mounting for rolling steel doors shall be either face-of-wall mounted or between-the-jamb mounted.

**11.1.2.2** The opening shall be protected by either a single or double door installation as determined by the AHJ.

**11.1.2.3** Rolling steel fire doors shall be permitted to be mounted to steel members set in or against the wall in accordance with their listing.

#### **11.3 Openings.**

**11.3.2** Where metal jambs are provided, only minimum  $\frac{3}{16}$  in. (4.76 mm) nominal structural steel or formed steel shall be used.

**11.3.3** Jambs shall be in accordance with the manufacturer's listing.

**11.3.4** Items that are not a part of the fire door assembly shall not be field attached to any component of a rolling steel fire door.

**11.3.5** Access to any clearances between surrounding construction and a rolling steel fire door shall allow for required testing and maintenance.

#### **11.4 Assembly Components.**

##### **11.4.1 Closing Devices.**

**11.4.1.1** An automatic-closing device shall be installed on every rolling steel door.

## ROLLING STEEL DOORS

**11.4.1.2** Rolling steel doors shall close automatically upon activation or release of a fusible link or detector.

**11.4.1.3** After automatic closing, the bottom bar shall come to rest in the closed position.

**11.4.1.5** Rolling steel fire doors shall have an average closing speed of not less than 6 in./sec (152 mm/sec) or more than 24 in./sec (610 mm/sec).

### **11.4.2\* Power-Operated Rolling Steel Fire Doors.**

**11.4.2.1** Power-operated fire doors shall be permitted to be furnished with a sensor that causes the door closer to stop or reverse upon contact with an obstruction under normal conditions.

**11.4.2.2** Power-operated rolling steel fire doors shall be equipped with an automatic-closing device that, upon activation, will cause the door to close.

**11.4.2.2.1** After automatic closing is activated, the door shall remain in the closed position until the automatic-closing device has been reset.

**11.4.2.2.3** When an automatic closing device is designed to open and reclose when encountering an obstruction, the unit shall be designed such that it can reopen a maximum of three times.

**11.4.2.2.3.1** After encountering an obstruction for the third time, the bottom bar shall come to rest on the obstruction.

### **11.4.3 Assembly of Rolling Doors.**

#### **11.4.3.1 Guides.**

**11.4.3.1.1** Guides for rolling steel fire doors shall be mounted either on the face of the wall or between the jambs, or a combination thereof.

**11.4.3.1.2** The guides shall be mounted plumb and with the required clearances to allow for vertical expansion when exposed to fire.

**11.4.3.1.3\*** The individual door manufacturer's written installation instructions and listing shall be consulted for the location and amount of clearance required.

**11.4.3.1.4** The guides shall be permitted to be either exposed or concealed in a pocket or wall reveal.

**11.4.3.1.5** Attachment of the guides to masonry wall construction shall be by means of through-wall bolts.

**11.4.3.1.6** Attachment of guides to a wall of non-masonry construction shall be in accordance with the manufacturer's written installation instructions and listing.

**11.4.3.1.7** As an alternative to 11.4.3.1.6, expansion anchors shall be permitted to be used in accordance with 4.8.6.

**11.4.3.1.8** Where metal jambs that have been designed to support the size and weight of the door assembly for its intended function are used, guides shall be bolted to the jambs.

**11.4.3.1.9** As an alternative to 11.4.3.1.8, guides shall be permitted to be welded to the jambs in accordance with the manufacturer's written instructions and listing.

#### **11.4.3.2 Hoods.**

**11.4.3.2.1** A hood shall be provided.

**11.4.3.2.2** Where a flame baffle is provided, a fusible link connection to the flame baffle shall be permitted to be independent of the detectors or fusible link connections that activate the door's automatic-closing device.

## **Annex A Explanatory Material**

*Annex A is not a part of the requirements of this NFPA document but is included for informational purposes only. This annex contains explanatory material, numbered to correspond with the applicable text paragraphs.*

**A.3.2.2 Authority Having Jurisdiction (AHJ).** The phrase "authority having jurisdiction," or its acronym AHJ, is used in NFPA documents in a broad manner, since jurisdictions and approval agencies vary, as do their responsibilities. Where public safety is primary, the authority having jurisdiction may be a federal, state, local, or other regional department or individual such as a fire chief; fire marshal; chief of a fire prevention bureau, labor department, or health department; building official; electrical inspector; or others having statutory authority. For insurance purposes, an insurance inspection department, rating bureau, or other insurance company representative may be the authority having jurisdiction. In many circumstances, the property owner or his or her designated agent assumes the role of the authority having jurisdiction; at government installations, the commanding officer or departmental official may be the authority having jurisdiction.

**A.3.3.49 Fire Door.** The fire protection rating of a fire door presumes that the door is installed with the appropriate frame, hardware, and other accessories required by this standard. In any instance where any of the required elements is omitted, the assembly rating is void for the purposes of this standard and the opening protection is not considered equivalent to the labeled or otherwise indicated fire protection rating of the door component.

**A.3.3.99 Rolling Steel Fire Door.** Rolling steel fire doors come in various sizes and can be used for different applications. The term *rolling steel fire door* as used by most manufacturers refers to a product that is intended for use in relatively larger openings. Such products generally utilize larger slat designs and more substantial guides for securing the assembly to the wall. Many manufacturers use the term *counter fire door* in reference to products that are typically designed for use on smaller openings such as counters. Their

construction is similar to the product that is manufactured as a rolling steel fire door except that the assemblies typically use smaller slat designs and formed steel sections for guides. Counter fire doors serve the same purpose and provide the same level of protection as rolling steel fire doors. *Counter fire door* is an industry-accepted term used for marketing purposes. NFPA 80 does not differentiate between these products. The requirements for rolling steel fire doors are intended to apply to products referred to as counter fire doors.

**A.4.9** Fire doors, shutters, or fire windows are of value only if properly installed so that they close at the time of fire. At the

time of the initial installation, each releasing means that part of the releasing system should be tested to verify that the door will close regardless of which fusible link is operated. This includes items such as heat or smoke detectors that might not have been installed by the fire door installer.

A written record documenting the installation and operational test(s) should be maintained on site by the person(s) responsible for keeping maintenance records. Various organizations have developed and make available test and maintenance forms specifically for this purpose.

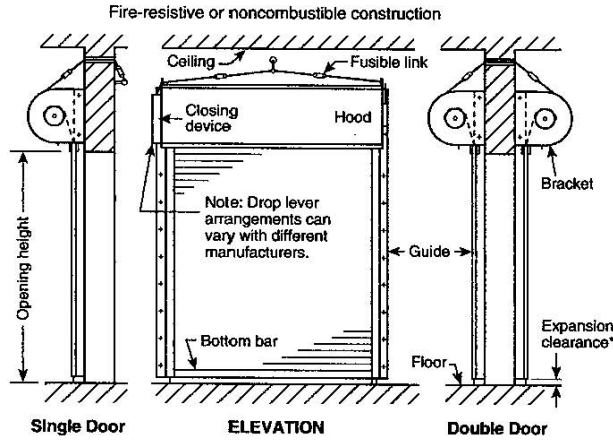

\* Expansion clearance per door listing. Doors with downward expansion are as shown. Doors with upward expansion require expansion clearance above the top of the door.

Note: Fusible links are needed on both sides of the wall — configuration could vary.

**FIGURE A.4.7.5(k) Rolling Steel Doors — Surface Mounted.**

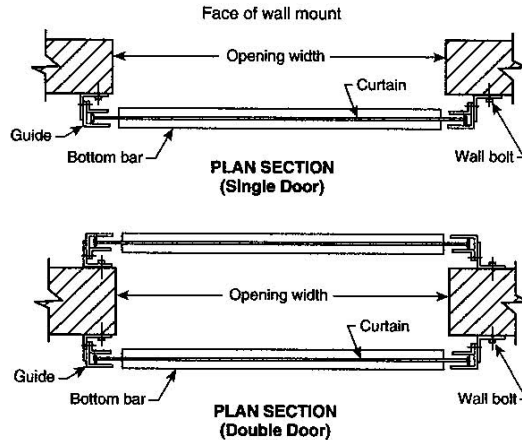

Wall bolt for masonry construction:  
Through-bolt, or expansion anchor, as permitted by door listing.

Wall bolt for nonmasonry wall construction:  
Through-bolt, or machine screw into steel jamb, or lag screw into wood jamb, as permitted by door listing.

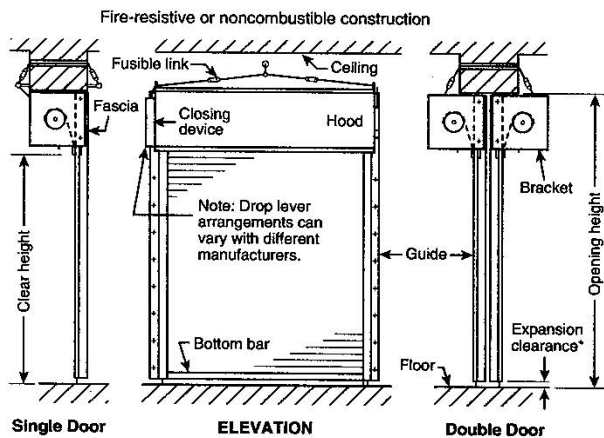

\* Expansion clearance per door listing. Doors with downward expansion are as shown. Doors with upward expansion require expansion clearance above the top of the door.

Note: Fusible links are needed on both sides of the wall — configuration could vary.

**FIGURE A.4.7.5(l) Rolling Steel Doors — Mounted Between Jambs.**

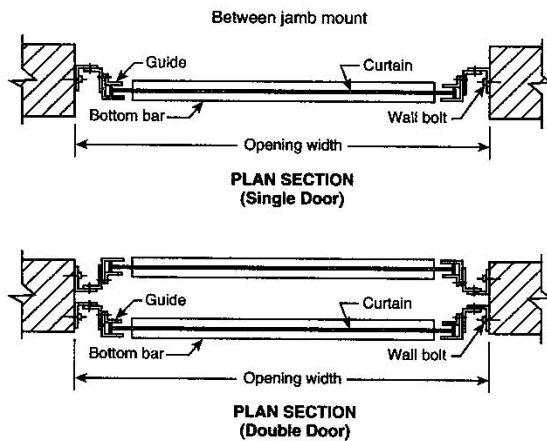

Wall bolt for masonry construction:  
Through-bolt, or expansion anchor, as permitted by door listing.

Wall bolt for nonmasonry wall construction:  
Through-bolt, or machine screw into steel jamb, or lag screw into wood jamb, as permitted by door listing.

Reprinted with permission from NFPA 80-2010, *Fire Doors and Other Protectives*, Copyright © 2010, National Fire Protection Association, Quincy, MA 02169. This reprinted material is not the complete and official position of the NFPA on the referenced subject, which is represented only by the standard in its entirety.

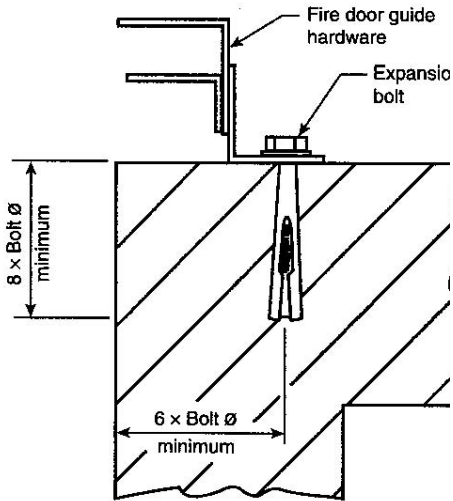

FIGURE A.4.8.6(a) Corner Walls.

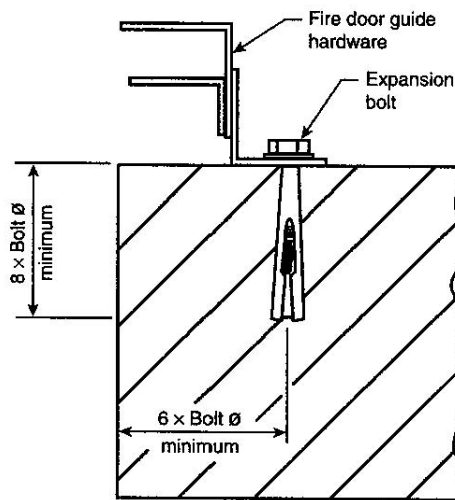

FIGURE A.4.8.6(b) Unusually Thick Walls.

**A.5.2** Fire doors, shutters, and windows are of no value unless they are properly maintained and closed or are able to close at the time of fire. A periodic inspection and maintenance program should be implemented and should be the responsibility of the property management.

### Annex K General Information About Fire Doors

*This annex is not a part of the requirements of this NFPA document but is included for informational purposes only.*

**K.2** Where fire doors are used in a means of egress, NFPA 101, *Life Safety Code*, specifies that they are required to swing with the exit travel except for doors on individual small rooms, which can be permitted to swing in; and that for horizontal exits, where fire doors are required on both sides of

the wall, one door can be permitted to be an automatic horizontally sliding door, normally open, and the other door can be permitted to be a self-closing door that swings with the exit travel, normally closed. The following types of doors might not be permitted to be used on exits:

- (1) Rolling steel doors or shutters
- (2) Vertical sliding doors
- (3) Jackknife doors

**K.7** Fire doors, shutters, or fire windows are of value only if properly maintained so that they close or are closed at the time of fire. Periodic inspection of doors, shutters, and fire windows, with immediate attention to any necessary repairs and correction of any defects that could interfere with operation, is an important responsibility of the management of the property. (*See Chapter 5.*)