

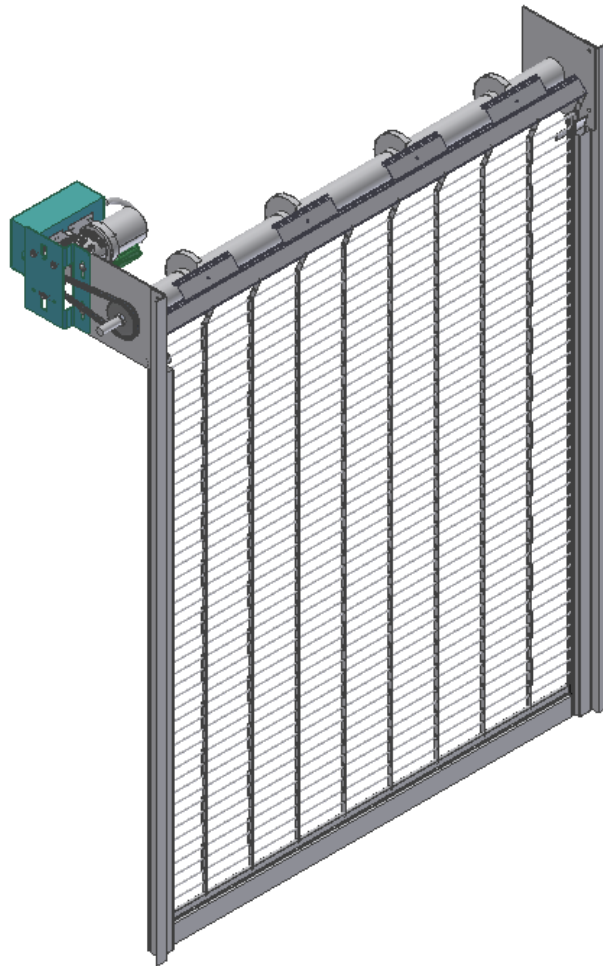

ACE GRILLE

ACCESS CONTROLLED EGRESS



Installation Instructions

The Cookson Company, Inc. ▪ 2417 S 50th Ave, Phoenix, AZ 85043 ▪ 800.294-4358 ▪ 602 272-4244 ▪ fax 866 448-6798 ▪
www.cooksondoor.com

Table of Contents

<u>TOPIC</u>	<u>PAGE</u>
<u>1. Part Inspection</u>	<u>2</u>
<u>2. Bellmouth Flaring</u>	<u>2</u>
<u>3. Guide Installation</u>	<u>3</u>
<u>4. Barrel Installation</u>	<u>8</u>
<u>5. Curtain Installation</u>	<u>10</u>
<u>6. Stopper Attachment</u>	<u>12</u>
<u>7. Spring Tension</u>	<u>12</u>
<u>8. Operator Installation</u>	<u>13</u>
<u>9. Setting Operator Limits</u>	<u>15</u>
<u>10. Hood Attachment</u>	<u>16</u>
<u>11. Maintenance</u>	<u>17</u>
<u>12. Fastener Torque Specifications</u>	<u>19</u>
<u>13. Acceptance of Installed Product:</u>	<u>20</u>

1. Part Inspection.

1.1 Unpacking:

1. Lay all of the ACE Grille components out to examine the parts, comparing them to the shop drawings of the unit enclosed with the grille system.
2. Inspect all parts for damage that may have occurred in shipping and verify that all necessary parts and hardware are present.
3. Typical hand tools are required for installation including; drill & drill bits (sized according to hardware supplied), screwdrivers, box wrenches, plumb bob, standard socket set, rubber mallet, light hammer, tape measure, level, marker or pencil, and pliers as well as peripherals such as ladders and lifting aids (large grilles).
4. See hardware list for grille system fastener information.

1.2 Work Area:

The key to a smooth installation is a clean and well-prepared work environment. With the entire ACE Grille inspected and the assembly and shop drawings reviewed, lay out the components in the order of installation.

1. The basic assembly sequence is as follows: guides, barrel w/ rings, brackets, motor operator, curtain, stoppers, and hood, when supplied.
2. The opening for the grille should be cleaned and inspected for rough surfaces, construction debris, dimensions matching that of the door and the shop sheet, square, and have a level floor.
3. Lastly the mounting hardware supplied in the grille system should correspond with the surface and construction features of the opening.

If there are any discrepancies with the product contact the Customer Service Department at The Cookson Company, Inc. immediately at 1.800.294.4358

2. Bellmouth Flaring.

1. Take the supplied guides and determine which end is the top by the location of the stopper attachment studs and the notch for the

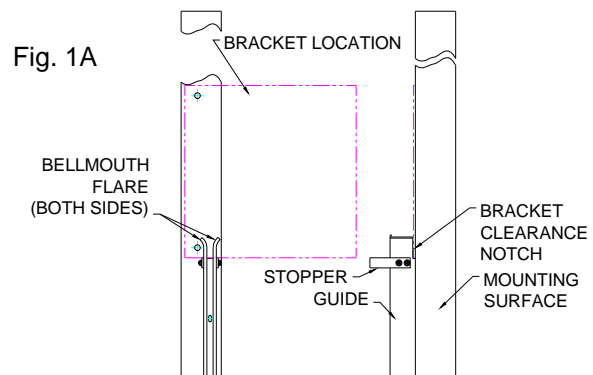

- bracket. The studs and notch will be on the top.
2. Flare the top of the guides at the bracket notch using a large adjustable wrench adjusted to fit the thickness of each leg of the extrusion.
 3. Bend each of the guide legs outwards to approximately thirty-degrees from the vertical installation plane for the length of the bracket clearance notch.

Note: The opening of the mouth should be between 2" to 2-1/4" wide. SEE FIGURE 1B.

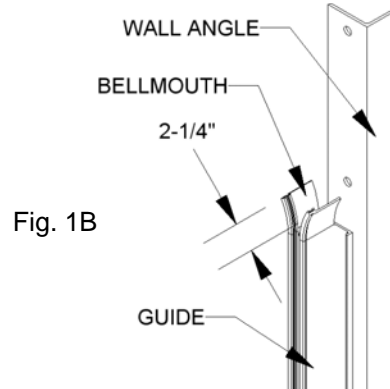

3. Guide Installation.

3.1 Face Mounted Guide Installation:

3.1.1 "E" Guides:

1. Check the supplied shop drawings for the build specifications. On the ACE Grille drawings there are measurements that will be used during the installation of the guides, specifically the measurement from heel-to-heel of the wall angles across the opening.
2. Measure the width of the opening and, using a plumb bob and marker, mark the center of the opening on the floor.
3. Measure from the center mark (Step #2) to half the width of the heel-to-heel dimension and place a mark on the wall. Do this for both left and right side and double check the full heel-to-heel dimension with the marks on the walls.
4. Remove the bolts that fasten the wall angle to the guide and place the guide off to the side.
5. Stand the wall angle up, mounting holes against the wall and toe of the angle pointing towards the center of the opening, and align the heel edge of the wall-mounting angle with the mark on the wall made previously (Step #3).

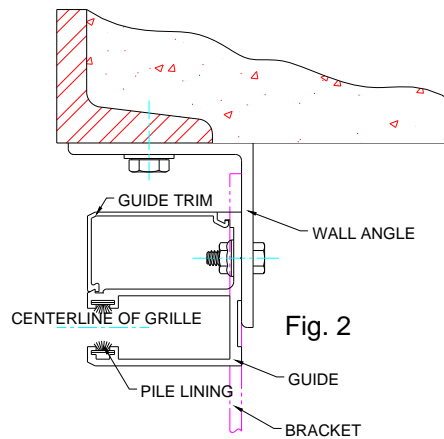

6. With the wall angle aligned on the mark, ensure the wall angle is plumb and mark the mounting holes of the angle on the wall. Be sure the end of the angle with the bracket mounting holes is at the top and the bottom of the angle is even with the opening.

The ends of both wall angles must be level with one another.

7. Place the wall angle off to the side and drill mounting holes with the appropriate size drill bit, fastener size listed on shop sheet, place and snug all bolts, and plumb before fully tightening to spec (Sec. 14).
8. Align the mounting holes in the guide extrusion with those in the wall angle. Mount the guide extrusions to the wall angles as in figure 3 with the stoppers upward and the bottom of the guide even with the bottom of the wall angle. It is important to assemble the guides according to the measurements on the shop sheet.
9. Snap the guide trim into place using a rubber mallet.

Both left and right wall angles and guides are attached in the same manner.

3.1.2 “Z” Guide:

1. Check the supplied shop drawings for the build specifications. On the ACE Grille drawings there are measurements that will be used during the installation of the guides, specifically the measurement from heel-to-heel of the mounting angles across the opening.
2. Measure the width of the opening and, using a plumb bob and marker, mark the center of the opening on the floor.
3. Measure from the center mark (Step #2) to half the width of the heel to heel dimension and place a mark on the wall. Do this for both left and right side and double check the full heel-to-heel dimension with the marks on the walls.
4. Stand the wall angle up, mounting holes against the wall and toe of the angle pointing away from the center of the opening, and align the heel edge of the wall-mounting angle with the mark on the wall made previously (Step #3).
5. With the wall angle aligned on the mark, plumb and mark the mounting holes of the angle on the wall. Be sure the end of the angle with the bracket mounting holes is at the top and the bottom of the angle is even with the opening.

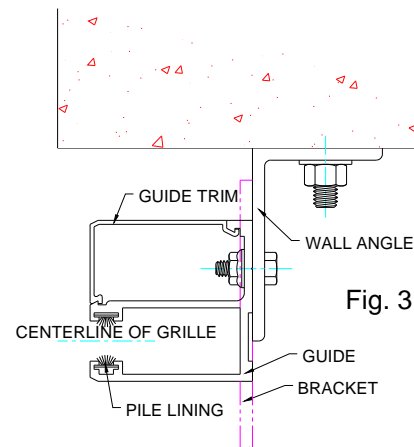

Fig. 3

6. Place the wall angle off to the side and drill mounting holes with the appropriate size drill bit, fastener size listed on shop sheet, place and snug all bolts, and plumb before fully tightening to spec (Sec. 14).
7. Align the mounting holes in the guide extrusion with those in the wall angle. Mount the guide extrusions to the wall angles as in figure 3 with the stoppers upward and the bottom of the guide even with the bottom of the wall angle. It is important to assemble the guides according to the measurements on the shop sheet.
8. Snap the guide trim into place using a rubber mallet.

Both left and right wall angles and guides are attached in the same manner.

3.2 Between Jamb Mounting

3.2.1 Flat Plate Mount:

1. Check the supplied shop drawings for the build specifications. On the ACE Grille drawings there are measurements that will be used during the installation of the guides, specifically the working dimension measurement across the opening.
2. First locate the centerline position of the grille. Measure and mark along the wall / jamb / floor where the centerline of the grille will be located. This mark will be the **centerline of grille**. Architectural drawings will denote the location.
3. In the center of the opening, measure and mark a line from the **centerline of grille** (Step #2) line in either direction 1-7/8" towards the fascia side of the curtain and 5/8" towards the bracket side. This will mark the edges of the wall flat.
4. Place the wall flat and guide on the jamb according to Fig. 4 at the edge marks on the jamb (Step #3). Check for plumb.
5. Mark the mounting holes on the jamb and place the wall flat and guide off to the side. **Make sure both the guide assemblies are level with each other.**
6. Drill the mounting holes on the marks (Step #5) examining the hardware sheet for the size and style of the fasteners. Select drill bit sizes accordingly.

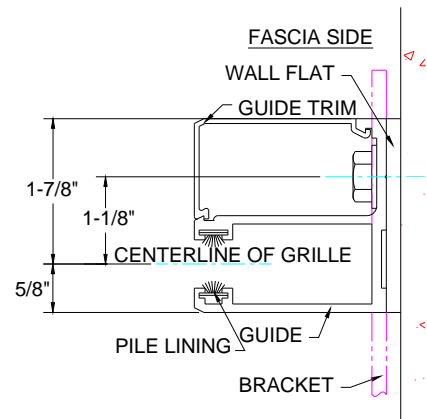

Fig. 4

7. Replace the wall flat and guide on the jamb, insert, and snug the mounting fasteners. Recheck for plumb and adjust if necessary.
8. Fully tighten the fasteners to spec (Sec. 14).
9. Snap the guide trim into place using a rubber mallet.

Both left and right wall flats and guides are attached in the same manner.

3.2.2 Without Wall Flat Mount: (Same as above)

1. Check the supplied shop drawings for the build specifications. On the ACE Grille drawings there are measurements that will be used during the installation of the guides, specifically the working dimension measurement across the opening.
2. First locate the centerline position of the grille. Measure and mark along the wall / jamb / floor where the centerline of the grille will be located. This mark will be the **centerline of grille**. Architectural drawings will denote the location.
3. In the center of the opening, measure and mark a line from the **centerline of grille** (Step #2) line in either direction 1-7/8" towards the fascia side of the curtain and 5/8" towards the bracket side. This will mark the edges of the guide.
4. Place the guide on the jamb according to Fig. 4 at the edge marks on the jamb (Step #3). Check for plumb.
5. Mark the mounting holes on the jamb and place the guide off to the side.
Make sure both the guides are level with each other.
6. Drill the mounting holes on the marks (Step #5) examining the hardware sheet for the size and style of the fasteners. Select drill bit sizes accordingly.
7. Replace the guide on the jamb, insert, and snug the mounting fasteners. Recheck for plumb and adjust if necessary.
8. Fully tighten the fasteners to spec (Sec 14).
9. Snap the guide trim into place using a rubber mallet.

Both left and right wall angles and guides are attached in the same manner.

3.2.3 Structural Steel Tube Mount:

1. Check the supplied shop drawings for the build specifications. On the

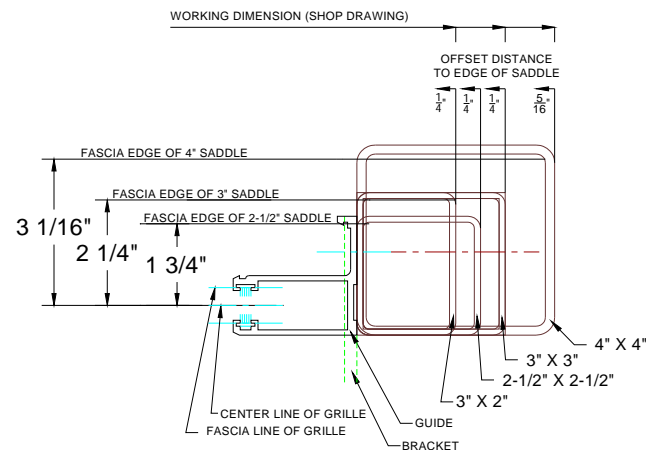

Fig. 5

ACE Grille drawings there are measurements that will be used during the installation of the guides, specifically the **working dimension** from outside of tube to outside of tube across the opening.

2. First locate the centerline position in the area where the centerline of the grille is to be installed. Measure and mark along the jamb / floor where the centerline of the grille will be located. This mark will be the **centerline of grille**. Architectural drawings will denote the location.
 3. Establish the center of the opening where the grille will be located and mark the center with a line parallel to the jamb.
 4. Measure from the center mark in either direction (Step #3) to half the distance of the outside of tube to outside of tube working dimension from the ACE shop drawings supplied in the kit. Place a mark on the floor or jamb and measure from mark to mark to verify the working dimension.
 5. On the jamb or floor there should now be intersecting marks that indicate the centerline of the grille and the outer edges of the tubes. Using Fig. 5 as a reference, mark the outside and fascia side edges of the saddle.
 6. Place the saddle according to the outside and fascia side edge marks, square the saddles with the opening, and locate the mounting holes on the floor.
 7. Place the saddle off to the side and drill the mounting holes for the 3/8" expansion anchors to a depth of 1-7/8".
 8. Replace saddles of the perspective mounting holes, insert the 3/8" expansion anchors and secure the saddle to the floor.
 9. Place the mounting tube over the saddle, plumb, and attach the supplied bracing angle(s) to the structure (if supplied).
- The bracing angle(s) can be welded to the existing construction but must be **BOLTED** to the mounting tube.

Both left and right wall angles and guides are attached in the same manner.

3.2.4 Aluminum Tube Mount:

1. Check the supplied shop drawings for the build specifications. On the ACE Grille drawings there are measurements that will be used during the installation of the guides, specifically the **working dimension** from outside of tube to outside of tube across

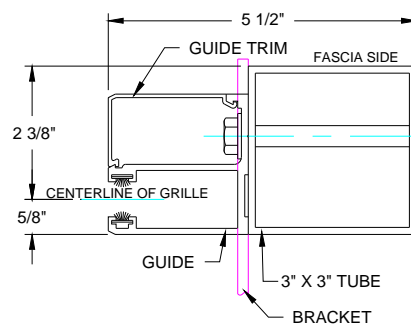

Fig 6.

- the opening.
2. First locate the centerline of the grille. Measure, square, and mark along the jamb / floor where the centerline of the grille will be located. This mark will be the **centerline of grille**. Architectural drawings will denote the location.
 3. Establish the center of the opening where the grille will be located and mark the center with a line parallel to the jamb.
 4. Measure off the line marking the center of the opening (Step #3) half the width of the working dimension towards either jamb. Place a mark and verify the full working dimension width from line to line.
 5. Where the **centerline of grille** is marked on the jamb, measure 2-3/8" towards the fascia side of the opening and mark a line on the floor square with the jamb.
 6. Place an aluminum tube upright next to jamb with the evenly spaced hole for mounting the guide down and facing the center of the opening.
 7. Move the aluminum tube against the jamb and align the fascia side of the tube with the mark on the floor (Step #5). Make sure the tube is plumb.
 8. Mark the locations for the wall fasteners from the tube on the jamb.
 9. Place the tube off to the side and drill the mounting holes on the marks (Step #8) for the fasteners supplied. Check the hardware sheet for fastener details.
 10. Mount the guide extrusion, stoppers up, to the aluminum tube with the supplied fasteners. Refer to Fig. 6.
 11. Replace the aluminum tube on the jamb over the mounting holes, plumb, and secure it with the fasteners supplied in the kit. Tighten to spec (Sec. 14).
 12. Snap the guide trim into place using a rubber mallet.

Both left and right wall angles and guides are attached in the same manner.

4. Barrel Installation.

4.1 Barrel Assembly and Bracket Preparation:

1. Determine the direction of rotation. To do this, examine which end of the barrel is the adjusting end defined by the markings on the barrel "LH or RH" (written on the respective side) and the numbers of turns required to charge the spring. Facing the guides from the bracket side match the appropriate designation on the barrel with the appropriate guide; "LH" adjustor designation to the left hand guide and "RH" adjustor designation to the right hand guide.
2. Place the barrel in front of the guides in this orientation on short blocks to raise it up off the ground two 2 – 4 inches. Notched 4x4 pieces of

wood are recommended, large doors will require higher blocks or suspension from above.

3. Remove the charge pin temporarily placed in the tension and the pin that secures the tension wheel to the inner shaft and remove the tension wheel from the inner shaft.
4. The barrel rings are always installed so when the curtain is attached to them it will reel the curtain onto the barrel in a clockwise rotation looking down the barrel from the left-hand side.
5. Ring types and installation guidelines:
 - Stamped rings: Slip the rings over the barrel noting direction of rotation and place above the tapped holes in the barrel. Insert 3/8-16 x 3/4 bolts and tighten to 20 ft / lbs.



Fig. 8

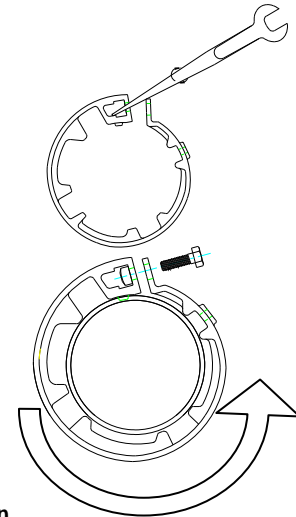

Rotation
direction
for curtain
raising.

Fig. 7

(Opt.) Cast Ring

(Std.) Stamped Ring

-Cast rings: Using a small pry bar or large standard screwdriver spread the gap in the ring 5/8" by prying between bolt flange and the nut cradle of the casting. With the gap spread the ring can be slid over the barrel. Rotate the ring so the locating hole in the barrel aligns with the locating tab in the casting. Insert the 3/8 – 16 square nut into the nut cradle of the casting and the 3/8-16 x 1-1/4" hex bolt through the bolt flange in the casting and tighten to 20 ft / lbs.

6. Identify the operator and adjustor bracket plates. The adjustor bracket plate will have a clip angle on it for the tension pin. The operator bracket plate will have mounting holes on opposite sides of the plate and a bearing fastened to it.
7. Slide the brackets over their respective sides with the shaft bearing and tension pin clip angle on the outside of the brackets facing away from the center of the barrel. Align the bearing properly on the inner shaft prior to sliding it onto the shaft.

4.2 Barrel Assembly and Bracket Installation.

1. With the brackets and barrel assembly prepared for installation, place a sling or lifting agent under the barrel assembly. If a forklift is to be used, lift the barrel slightly off center towards the adjuster end of the barrel assembly, being cautious the barrel does not roll off the forks and that it balances on the forks.

The barrel is heavier on the adjuster end, lift accordingly.

2. Center the barrel assembly between the guides, maintaining about two feet between the guides and brackets for lifting clearance, and raise the barrel assembly up to the approximate bracket mounting level.
3. Maneuver the barrel with brackets attached inward slowly, aligning the mounting holes of the guides and brackets. The brackets will mount on the inside of the wall angle, flat, or tube. (See Fig. 8)
4. Place a flat washer on each of the bolts, insert the bolts through the mounting holes from the bracket side first and then install the lock washer and nut. Tighten all the bolts.
5. Check spacing between the edges of the barrel and the brackets. Each side should be equal. Adjust as necessary.
6. Reinstall the tension wheel and replace the tension wheel pin.

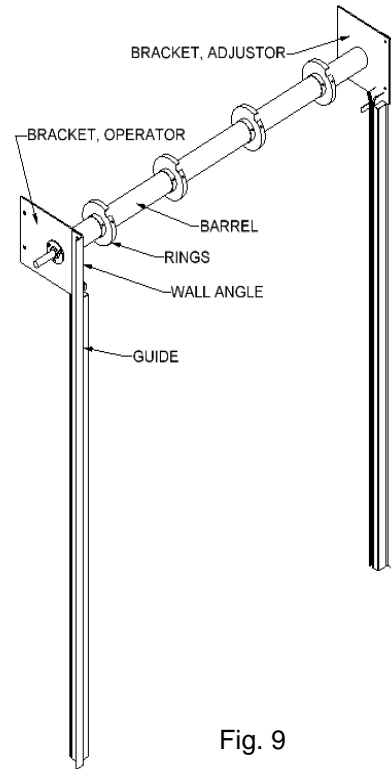

Fig. 9

5. Curtain Installation.

1. Lift the grille onto blocks placed on the barrel side of the curtain in front of the opening. The blocks should be spaced on 8-foot centers and at least 2 should be used. The starter slats should be pointing upward so the grille will wrap behind the barrel.
2. Prepare to lift the grille. Lifting the grille requires the use of a lifting agent such as a hoist(s) or a forklift. On grilles larger than 25 feet multiple lifting points are to be used to avoid damage. The lifting

points should be centered and spaced 10 feet on center. When using a hoist, route the rigging between the barrel and the mounting wall.

3. Using the appropriate lifting equipment and lifting points raise the grille coil to within 12 inches of the barrel and center it between the guides.
4. Suspend the curtain using rope slings looped around the barrel and the grille. The rope slings should be spaced along the width of the curtain at 8-foot intervals. (Fig. 9)

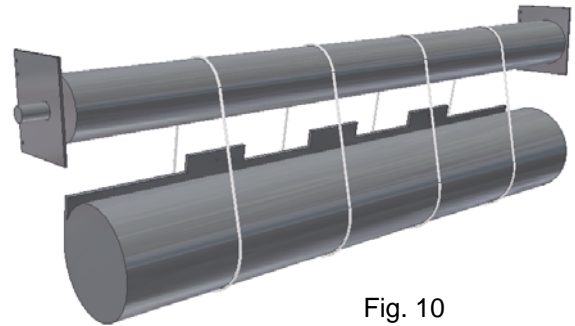

Fig. 10

5. Center the grille between the brackets, there should be an equal amount of space between the grille and the bracket on each side.
6. Pull the starter slats up to the barrel ring, align the holes, and secure with $\frac{3}{8}$ " – 16 x $\frac{3}{4}$ " bolts and flat washers provided in the hardware kit.

Tips:

-To aid in attaching the starter slats a rope may be tied through the mounting hole of the starter slat and routed over the barrel and down to the floor. Pulling on this rope will raise the starter slats to the mounting holes in the barrel.

-Rotate the barrel to align the starter slat / ring hole.

Only use hardware provided in the kit and noted on the hardware sheet.

7. After all the starter slats have been attached tighten the bolts.
8. Wind the grille onto the barrel:

-Manual chain operation: Make sure the charge pin is not inserted in the tension wheel and using the chain operator wind the curtain onto the barrel until the bottom bar clears the top of the guides.

-Motor operator: Make sure the charge pin is not inserted in the tension wheel and depress the UP button at the operator station. Keep an eye on the limit nuts in

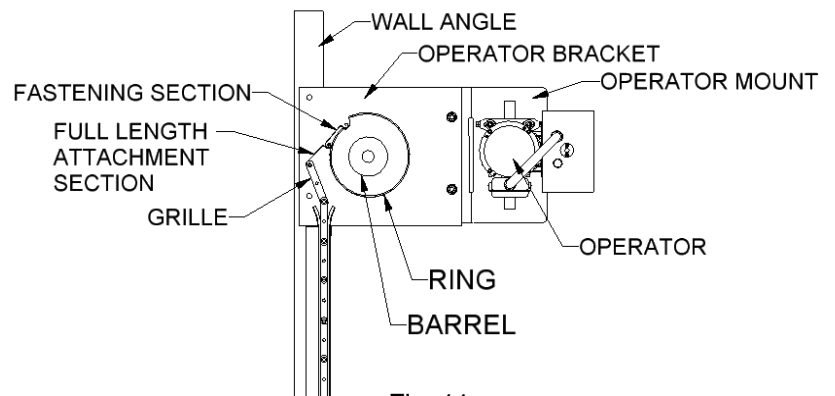

Fig. 11

the operator electrical box so they are not over run. Stop the grille when the bottom bar passes the top of the guides.

-Tension wheel winding: Locate the charge pin and charge adjustment bar(s) supplied in the kit. Insert the charge adjustment bar into the tension adjustment wheel, remove the charge pin, and turn the tension wheel in the direction to raise the curtain setting the charge pin when resetting the charge adjustment bar.

Note the amount of turns applied to the tension wheel before it began to roll the curtain onto the barrel.

9. Replace the charge pin leaving the rope slings in place.

6. Stopper Attachment:

1. With the curtain in the up position and the bottom bar higher than the top of the guides, lower the bottom bar through the bellmouth and into the guides.
2. Allow the bottom bar to pass the stoppers on the guides and stop the grille.
3. Remove the factory-attached stoppers and hardware and reinstall with the stopper overhanging towards the middle of the grille.

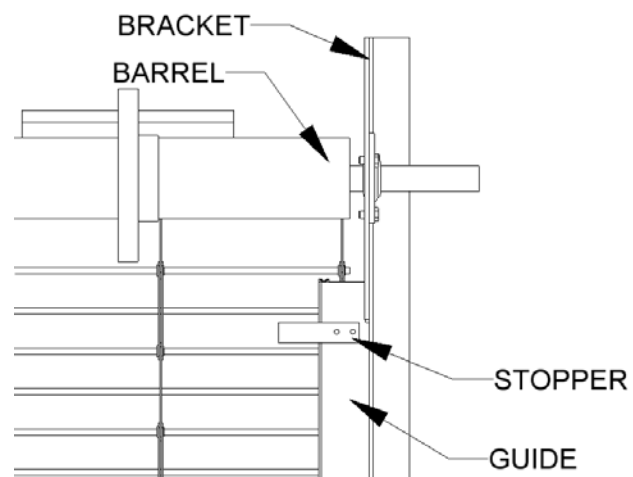

Fig. 12

reinstall with the stopper overhanging towards the middle of the grille.

THERE ARE 4 STOPPERS TOTAL

7. Spring Tension:

1. Insert the spring retaining pin into the charge pin.

8. Motor Operator Installation.

8.1 Operator Mounting:

1. Locate the operator-mounting bracket and bolts provided with the operator.

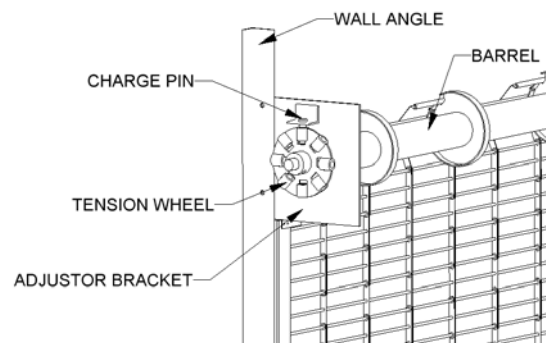

Fig. 13

2. Compare the mounting bracket to the mounting foot of the operator to familiarize yourself with the mounting holes and the notch in the plate that the chain will run through.
3. There are different types of mountings that can be arranged with the supplied components. Examine the shop drawings and components supplied with the kit and identify the specific style of mounting ordered for the unit.
4. Mount the operator-mounting bracket over the operator side bracket according to the shop drawing with the fasteners supplied in the kit. Attach all mounting pieces prior to attaching the motor operator.
5. Mount the operator in the holes noted on the shop drawing.

SEE SHOP DRAWING FOR DETAILS.

The Following Steps Are For Attaching Additional Bracing:

- a) Attach a clip angle to the operator mounting bracket and the bracing angle to the clip angle and snug all bolts.
- b) Mount the other supplied clip angle to the bracing angle and swing the bracing angle to the wall or structural support.
- c) Align the mounting face of the clip angle with the face of the wall or support, mark and drill a mounting hole for the size of the supplied mounting fastener, and secure the clip angle to the wall or support with the fastener.

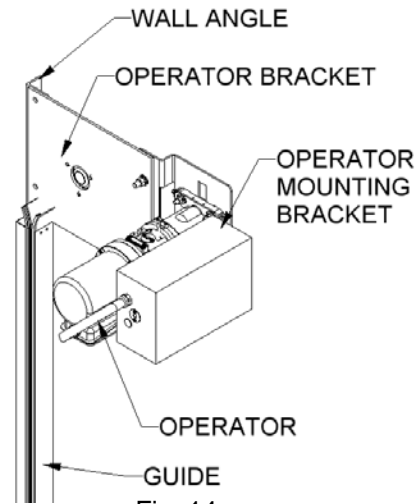

Fig. 14

- d) Square the operator-mounting bracket, adjusting the bracing angle as necessary, and fully tighten all the mounting bolts.
- e) Lift the motor operator into position on the mounting bracket and align it with the appropriate hole pattern.

6. Insert the fasteners included in the kit from the mounting plate side first into the mounting foot of the operator and tighten the nuts with lock washers.

**All Mounting Bolts Are Supplied
With Nuts and Lock Washers.**

7. Place and align the sprockets (small diameter on the motor operator and large on the barrel gear end) and insert the keys.

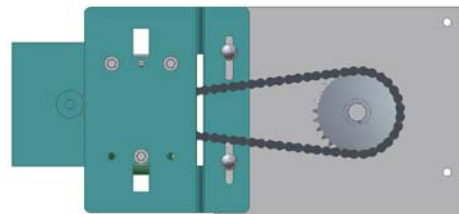

Fig. 15

8. Tighten the setscrews on the sprockets.
9. Install the chain and tension it so there is no slack.
10. The chain may have to be cut to length. To do this:
 1. Loosen mounting bolts at base of operator.
 2. With the chain adjustment jamb bolts move the operator towards the barrel the full amount of travel.
 3. Place the chain over each sprocket and with a marker mark the length to be removed. The mark must be on a pin that will leave an inner link exposed after the length is removed.
 4. Remove the pin with a grinder and tap the pin out with a punch or using a chain breaker separate the two lengths.
 5. Replace the chain over the sprockets and install the master link.
 6. Adjust the chain until there is no slack and tighten the lock nuts on the adjusters.
11. Fully tighten all operator-mounting bolts and lock the jamb nuts on the adjusting screws.
12. Lubricate the AutoLock mechanisms on the curtain with an all-purpose spray lubricant.

8.2 Operator Electrical Box Connections (FS operators):

Make sure power is disconnected from the unit before any work is done!

1. Retrieve the electrical schematic located in the electrical control box of the operator, the control station(s), and the sensing edge if so equipped.
2. Referencing the electrical schematic connect the alarm relay contactor.
Ref: Contacts #11 & #12 on Terminal Block #5
3. Connect the sensing edge, if so equipped, to the terminal block.
Ref: Contacts #5 & #6 on Terminal Block #5
4. Connect control station wires to the terminal block.
Ref: Contacts #1 - #4 on Terminal Block #5
 - #1 – Stop
 - #2 – Up
 - #3 – Down
 - #4 – Common
5. Connect the power to the control box.
Ref: Inputs L1 & L2 on Terminal Block #1
6. With the power connected adjust the upper and lower limit switches so that they are not triggering the micro switch. Depress the spring-loaded locking plate and move each of the limit nuts to the middle of travel making sure they do not touch. Release the locking plate and turn the limit nuts slightly to lock them in position on the locking plate.
7. Test the operator for operational functions.

9. Setting Operator Limits:

These instructions are for operators mounted on the right-hand side of the barrel. Left-hand operators will follow the same procedure but the limit nuts will be on opposite sides.

1. Open the operator electrical box and examine the placement of the white limit nuts on the threaded shaft.
2. Depress the locking plate behind the limit nuts and spin both of the limits to the center of the threaded shaft.
3. Release the locking plate and slightly rotate each of the limit nuts to lock the groove of the nut to the flange on the locking plate.
4. Lower the grille to within 2 feet of the floor using the operator.
5. Depress the locking plate and move the lower limit (right-hand) nut toward the microswitch (right-hand side of the box) until the limit nut touches the switch.
6. Release the locking plate and rotate each of the limit nuts to align the locking groove.
7. Test the lower limit using the operator to lower the grille keeping a finger on the stop button. If the bottom bar contacts the floor and the operator doesn't stop, depress the stop button on the control.
8. Adjust the lower limit in 1 – 2 notch increments noting:
Moving the lower limit nut right will lower the stop position.
Moving the lower limit nut left will raise the stop position.
9. With the lower limit set, raise the grille to within 2 feet of the stoppers using the operator.
10. Depress the locking plate and rotate the upper limit nut (left hand) towards the microswitch (left hand side of the electrical box) until the base of the nut rests against the switch.
11. Release the locking plate and rotate each limit nut slightly to align the locking groove.
12. Test the upper limit using the operator to raise the grille toward the stoppers. Keep a finger ready to depress the stop button if the top of the bottom bar does not stop within 6 inches of the stoppers.
13. Adjust the upper limit in 1 – 2 notch increments noting:
Moving the upper limit nut left will lower the stop position.
Moving the upper limit nut right will raise the stop position.
14. After the limits are set test the grille operation a few times, look for:
 - Correct stopping positions.
 - Straight coiling of the grille links.
 - Grille does not rub the brackets.
 - Chain tension correct.
 - No scraping or grinding noises.
15. Test the grille for proper function:
 - With the grille fully, 70%, and 40% closed cut power to the unit and the grille should automatically rise to the stoppers.

-With the grille fully closed signal the alarm and the grille should automatically rise to the stoppers.

*If the grille does not rise fully or raises too fast the spring tension will have to be reset. See section 7 for details.

10. Hood Attachment.

10.1 Hood Installation:

1. Review the shop sheet under the hood heading and determine what components came with the system for hood and/or fascia attachment.
2. For long hoods (hoods over 12' in length made from stainless or aluminum and over 14' in length made of galvanized steel) there will be a support supplied and the hood will consist of two or more segments.
3. Examine mounting conditions: Three sided angular hoods mount over the brackets. A removable soffit can be specified for the under side of the curtain on three sided hoods.
4. Measure the distance outside the brackets (for three-sided hood) and compare with the shop sheet hood length. For hoods supplied with a support mark the center distance on the adjacent construction.
5. Attach the hood support to the construction in front or above the coil with the supplied hardware at the center. Level the support with the mounting clips on the brackets. Check on the hardware sheet for the fastener information. IF APPLICABLE.
6. Place the hood over the curtain and fit to the clip angles. Be sure the hood is square and flush on each side with the outside edge of the brackets on three sided hoods. Push the hood towards the curtain until the top edge of the hood rests against the mounting clips and the building construction, the left and right edges meet the inside edge of the brackets, and it is square with the brackets.
7. For segmented hoods align one edge of the hood with the attachment clip angles on the bracket and the other with the center of the hood support. Start from one side and work to the other.
DO NOT OVERLAP THE SEGMENTS
8. Secure the hood with the Tek fasteners supplied in the hardware kit to the mounting clips on the brackets and the hood support.

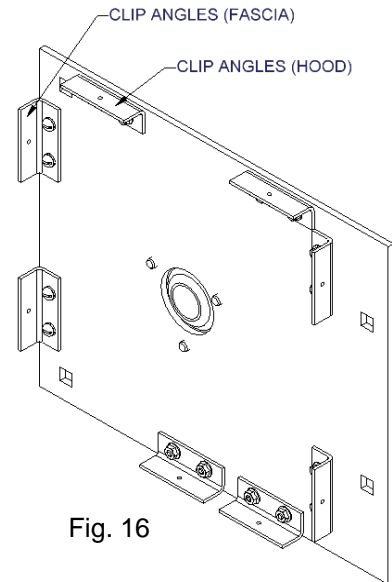

9. Place the hood splice cover over the joint of the hood segments centered on the joint.

10.2 Fascia Installation:

1. The fascia will cover the mechanism opposite the coil side covering the curtain coil when viewed from the fascia side of the curtain. Measure outside of mounting clip to outside of mounting clip on the side of the guides opposite the coil. Double-check this dimension against the supplied fascia.
2. Lift the fascia to the mounting clips raising it up until the top of the fascia is level with the top of the brackets. Center the fascia between the guides, level, and attach with the supplied Tek bolts to the mounting clips.

10.3 Operational Test:

1. With the hood and / or fascia attached, general assembly complete, and the electrical connections finished, test the door for operation.
2. Listen for:
 - Grinding noises.
 - Spring squeaking.
 - Grille contact with hood.
 - Electrical operator / drive train binding.
3. Look for:
 - Excessive bracket movement.
 - Grille coiling straight.
 - Correct speed up and down. (6 – 9 inches per second)
 - Correct control operation.
4. Make any adjustments necessary to solve any detected problems referring to the associated portion of the installation manual for assistance.
5. Test the AutoLock mechanisms by pulling up on the curtain below the lock and verify function. The lock will engage stopping the curtain.

11. Maintenance:

11.1 Maintenance Summary:

The ACE Grille requires little maintenance to provide a long and reliable service life. The maintenance steps highlighted in this section should be performed at the intervals recommended on the Routine Maintenance Schedule (APPENDIX #1). All work performed on the

grille should be done by a qualified facility maintenance technician or a rolling door professional. The suggested time frame to schedule a technician to examine the grille assembly is one year barring no damage or excessive wear detected by the facility manager.

11.2 Routine Maintenance Steps:

1. Inspect grille for alignment, level, and proper working clearances.
2. Check grille for damaged, loose, or missing clips and grommets.
3. Check guide extrusions for damage and secure attachment.
4. Inspect stoppers for damage and secure attachment.
5. Inspect guide felt for damage or tears.
6. Examine curtain to barrel attachment.
7. Inspect brackets for secure attachment. Check grille to bracket clearance and verify there is no interference between the grille and the bracket. Clearance should be equal on each side.
8. Test the grille operation for proper spring tension by tripping the alarm signal and removing power to the motor operator and watch the grille raise. Test at fully closed, 70% closed, and 40% closed.
9. Lubricate the Auto-Lock mechanisms once a year or every 2,500 cycles.
10. Operate the door while watching grille movement, correct any deficiencies which may cause the grille to catch or snag.
11. Inspect, align, tension, and lubricate the chain.
12. Check tension wheel and charge pin for damage and secure installation.
13. Check hood for proper attachment.

11.3 Motor Operator Maintenance:

1. Test motor operation through all control stations.
2. Check limit switch operation.
3. Examine sensing edge, coil cord, or take up reel for damage.
4. Test operation of sensing edge.
5. Inspect the wiring panel for debris, arching, or moisture. Check for and tighten loose wiring connections.
6. Verify that all conduit connectors are tight and have no exposed wires.
7. Check wires to the sensing edge (if applicable).
8. Inspect roller chain and drive sprockets. Align, lubricate the sprockets, and tighten the setscrews. Adjust the chain tension.
9. Generally inspect the motor mounting and tighten the fasteners and bracing.
10. Check all wiring connections for tightness and wire insulation defects of abrasion.

11. Check motor amperage draw for a full open and close cycle. Compare the readings to the numbers listed in the amperage table provided by the motor manufacturer.

11.4 Recommended Lubricants:

To Lubricate:	Use:
Roller Chains	Roller chain lubricant with penetrating agent Available in spray can.
Bearing With Grease Fittings	Multipurpose grease.
Lock Mechanisms and Stub Shafts	General-purpose lubricant in spray form.

12. Fastener Torque Specifications.

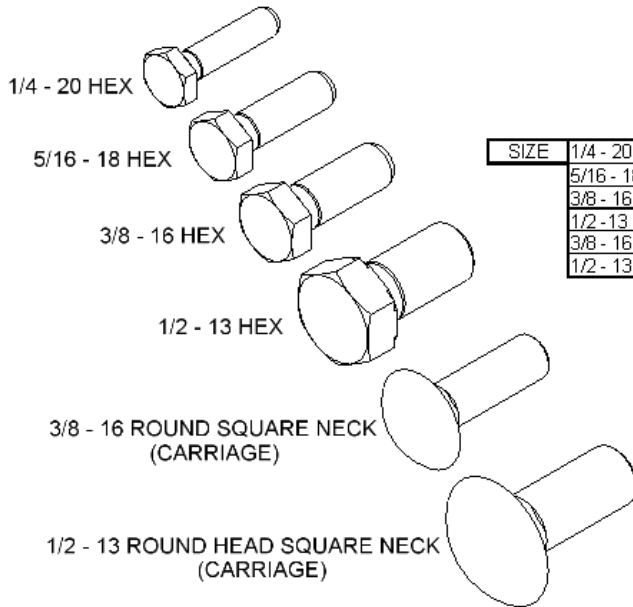

SIZE	GRADE		
	A	5	8
1/4 - 20 HEX	5.5		
5/16 - 18 HEX	11.5		
3/8 - 16 HEX	20		44
1/2 - 13 HEX	50		106
3/8 - 16 CARRIAGE		31	
1/2 - 13 CARRIAGE		75.5	

TORQUE (FT / LBS)

Acceptance of Installed Product: ACE (ACCESS Controlled Egress) Grille

Project _____ Contact _____ Phone _____

Address _____ City _____ State _____ Zip _____

Date _____ Serial Numbers _____

Visual Inspection Completed

Operational Inspection
And Testing Completed

Additional Notes: _____

The ACE (ACCESS Controlled Egress) Grilles on this project have been installed in accordance with the manufacturer's installation instructions. The automatic opening capabilities have been tested to demonstrate proper operation and full opening. The grilles have been reset in accordance with the manufacturer's instructions and left in proper working condition. In addition, I have read and understand the proper usage of the ACE (Access Controlled Egress) Grille and its annual testing and maintenance requirements.

Required annual maintenance and testing is to be performed by installing distributor:

Yes

No

Installed by _____

Witnessed by _____

Company _____

Representing _____

Address _____

Signature _____

Signature _____

Date _____

Date _____

NOTE: Signed form to be kept in the distributor's job file.