Maintenance Manual

for

Manually & Motor Operated
Service Doors
and
Insulated Service Doors



The Cookson Company

800 Tulip Drive • Gastonia, NC 28052

2417 South 50th Avenue • Phoenix, AZ 85043

Effective June 2007

Cookson Job No. _____

Job Name _____

This troubleshooting manual has been specifically written to provide a concise source of information to all customers of THE COOKSON COMPANY. This information will provide solutions to the most common problems and establish a systematic sequence required to repair a rolling door.

PURPOSE

When a problem is encountered that is not covered in this manual, please consult your authorized Cookson Company Distributor. The customer service department stands ready to assist you in locating your nearest authorized distributor. Our customer service department is available Monday through Friday 8:00 AM Eastern Time to 5:00 PM Pacific Time.

CUSTOMER SERVICE

Phone – (800) 390-8590

Fax – (704) 867-6101

When requesting information or ordering replacement parts, you must provide the following information to the Cookson Company Authorized Distributor.

ITEM

1. Cookson Job Number
2. Door Mark
3. Operator Voltage & Phase
4. Operator Model Number
5. Job Location

<p>NOTE: For maintenance or repair of this door, please consult your local authorized Cookson Distributor.</p>
--

PARTS LIST:
FACE MOUNTED,
PUSH-UP OPERATED
SERVICE DOOR

NO.	ITEM
1	Hood
2	Tension Spring
3	Tension Bracket
4	Bottom Bar
5	Stops
6	Barrel
7	Drive Bracket
8	Tension Wheel
9	Curtain
10	Guides

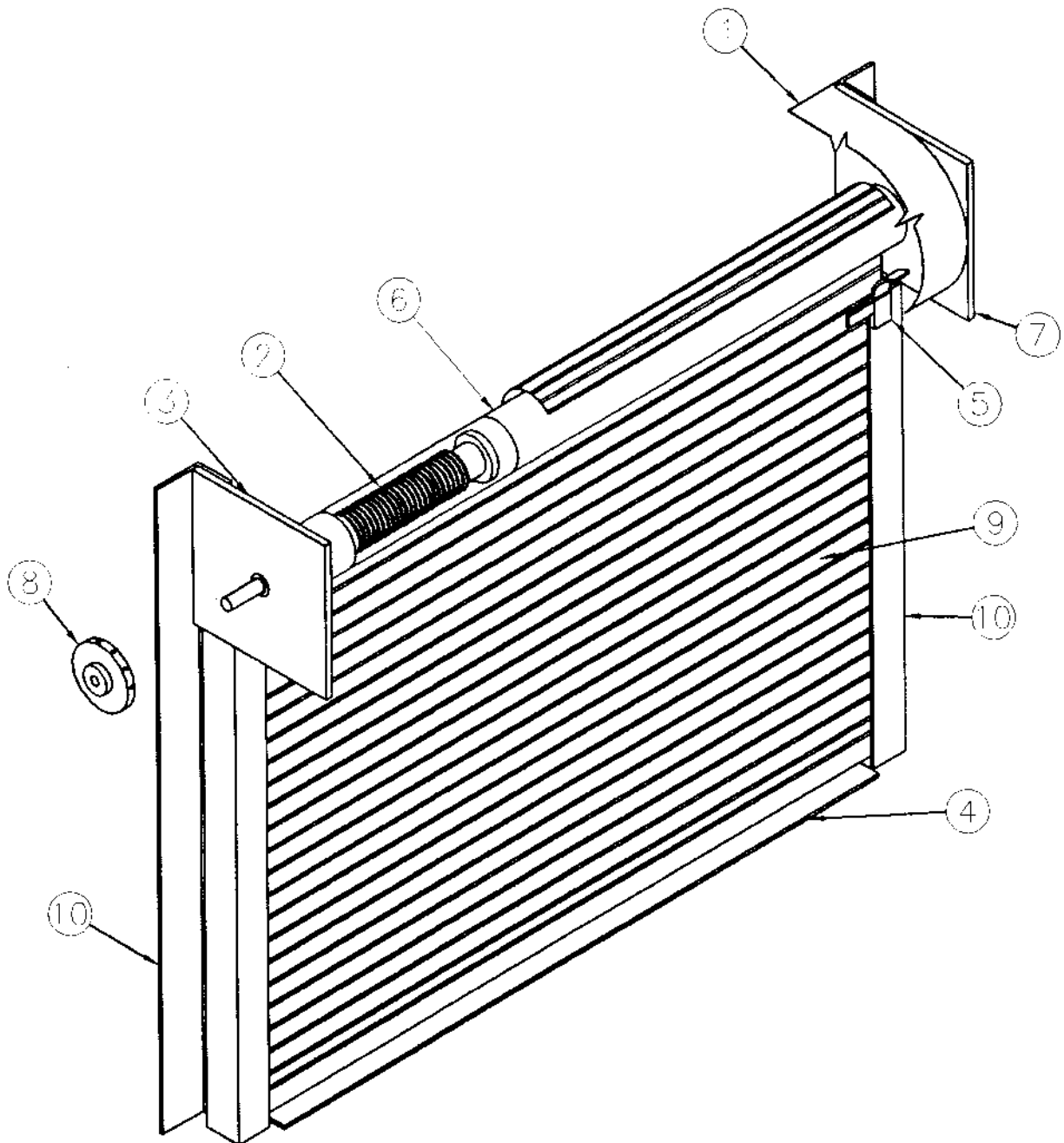

NO.	ITEM
1	Hood
2	Tension Spring
3	Drive Bracket
4	Bottom Bar
5	Stops
6	Tension Bracket
7	Tension Wheel
8	Curtain
9	Guides
10	Fascia
11	Barrel

PARTS LIST:
BETWEEN JAMB,
PUSH-UP OPERATED
SERVICE DOOR

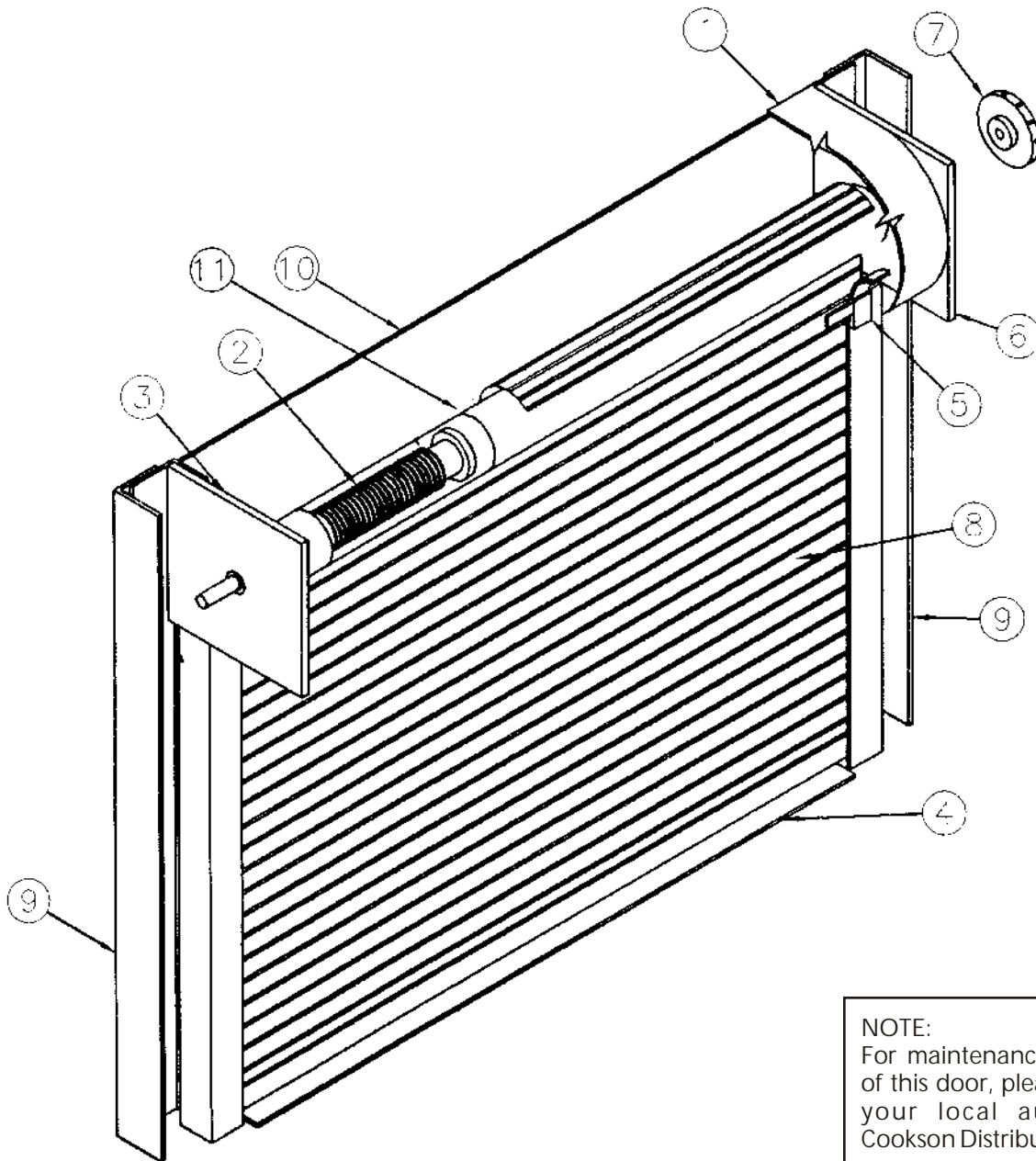

NOTE:
For maintenance or repair
of this door, please consult
your local authorized
Cookson Distributor.

PARTS LIST:
FACE MOUNTED,
CHAIN OPERATED
SERVICE DOOR

NO.	ITEM
1	Hood
2	Tension Spring
3	Drive Bracket
4	Main Gear
5	Intermediate Gears (Where Required)
6	Chain Guard w/ Chain Gear
7	Tension Bracket

NO.	ITEM
8	Tension Wheel
9	Curtain
10	Guides
11	Bottom Bar
12	Stops
13	Hood Support (where required)
14	Barrel

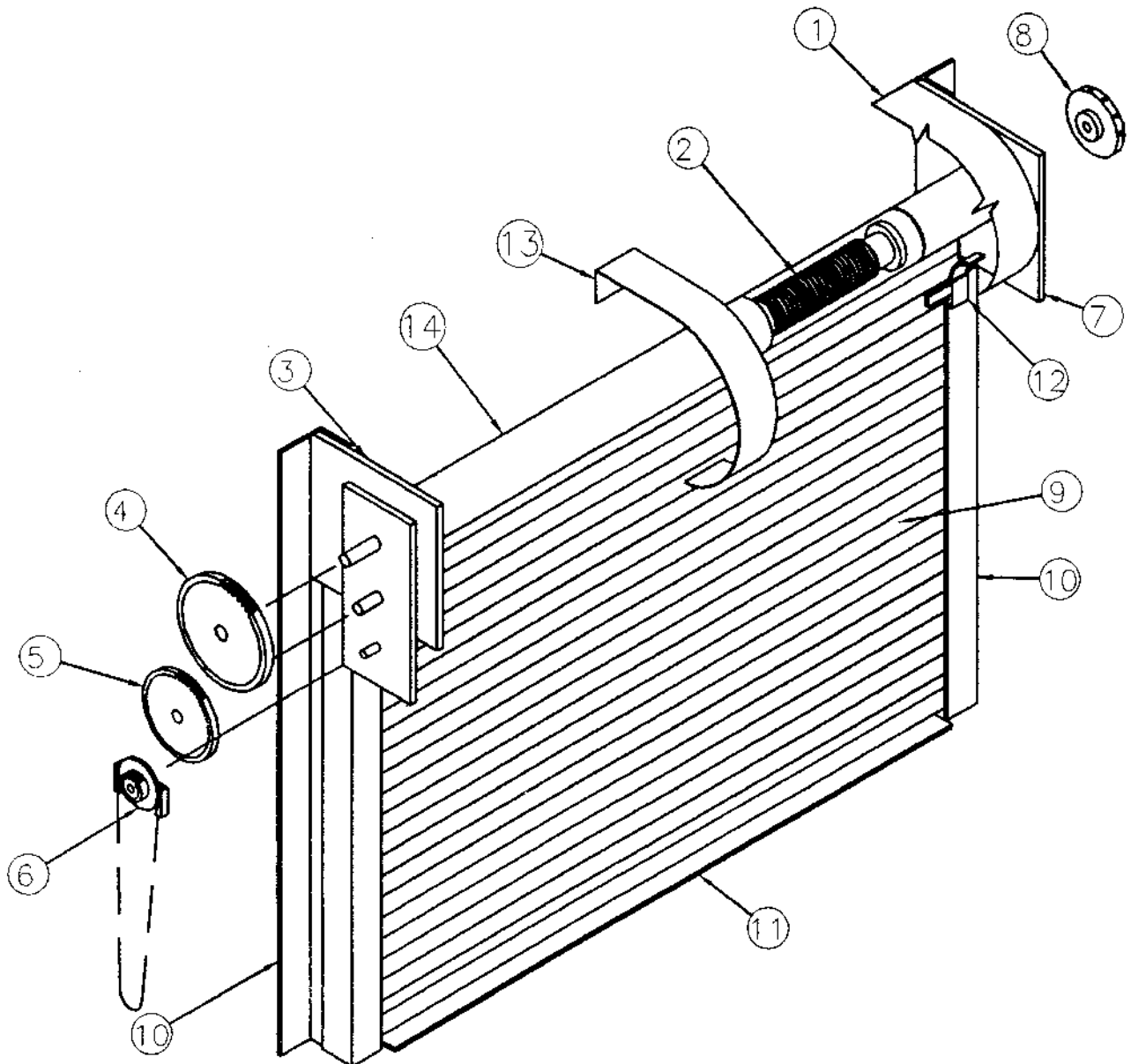

NO.	ITEM
1	Hood
2	Tension Spring
3	Drive Bracket
4	Main Gear
5	Intermediate Gears (Where Required)
6	Crank Operator w/ Handle
7	Tension Bracket

NO.	ITEM
8	Tension Wheel
9	Curtain
10	Guides
11	Bottom Bar
12	Stops
13	Hood Support (where required)
14	Barrel

PARTS LIST:
FACE MOUNTED,
CRANK OPERATED
SERVICE DOOR

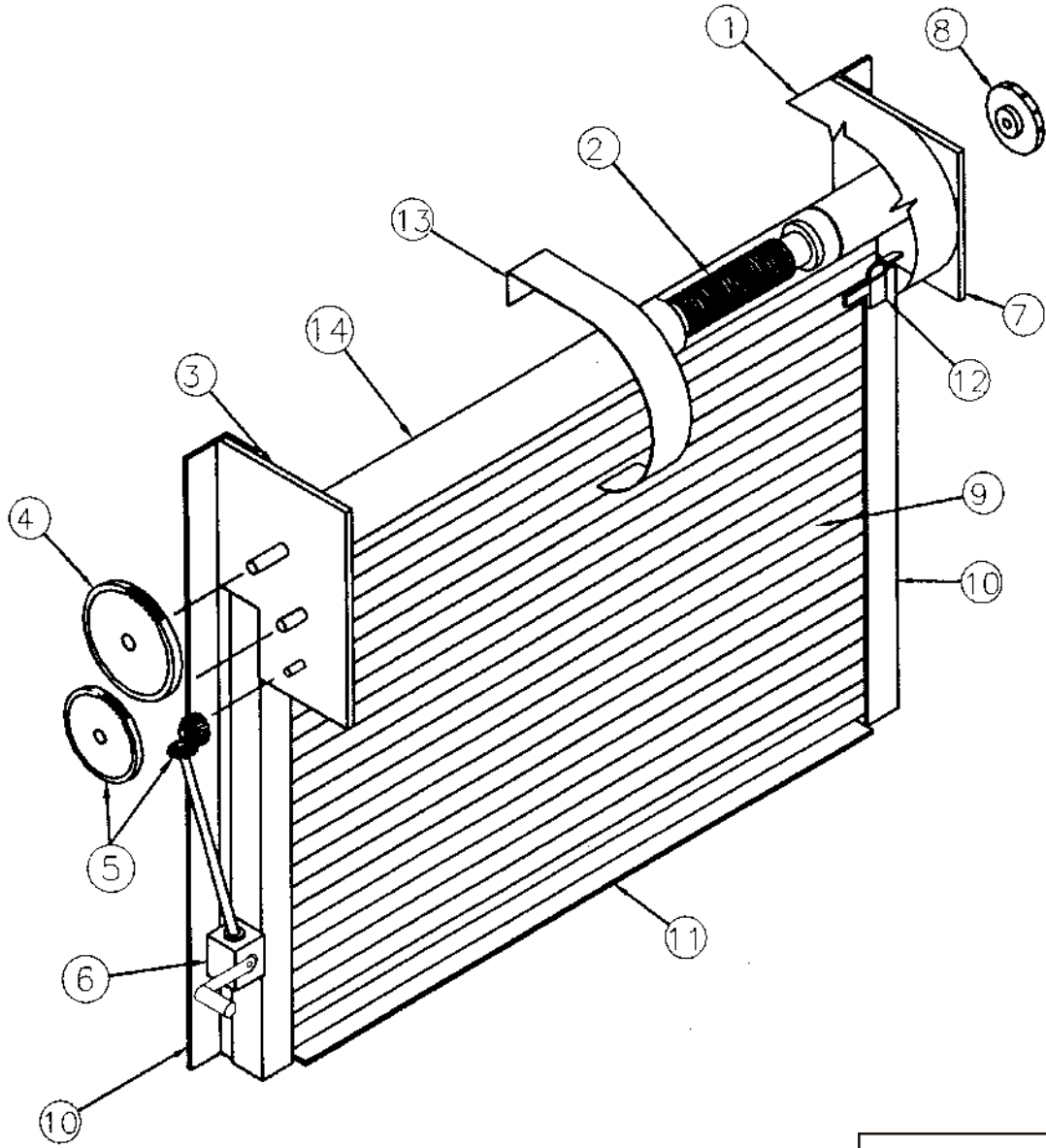

NOTE:
For maintenance or repair
of this door, please consult
your local authorized
Cookson Distributor.

PARTS LIST:
FACE MOUNTED,
CHAIN OPERATED,
INSULATED SERVICE
DOOR

NO.	ITEM
1	Hood
2	Tension Spring
3	Drive Bracket
4	Main Gear
5	Intermediate Gears (Where Required)
6	Chain Guard w/Chain Gear
7	Tension Bracket
8	Tension Wheel

NO.	ITEM
9	Curtain
10	Guides
11	Bottom Bar
12	Stops
13	Hood Support (where required)
14	Barrel
15	Hood Baffle
16	Weatherstripping
17	Hoops (where required)

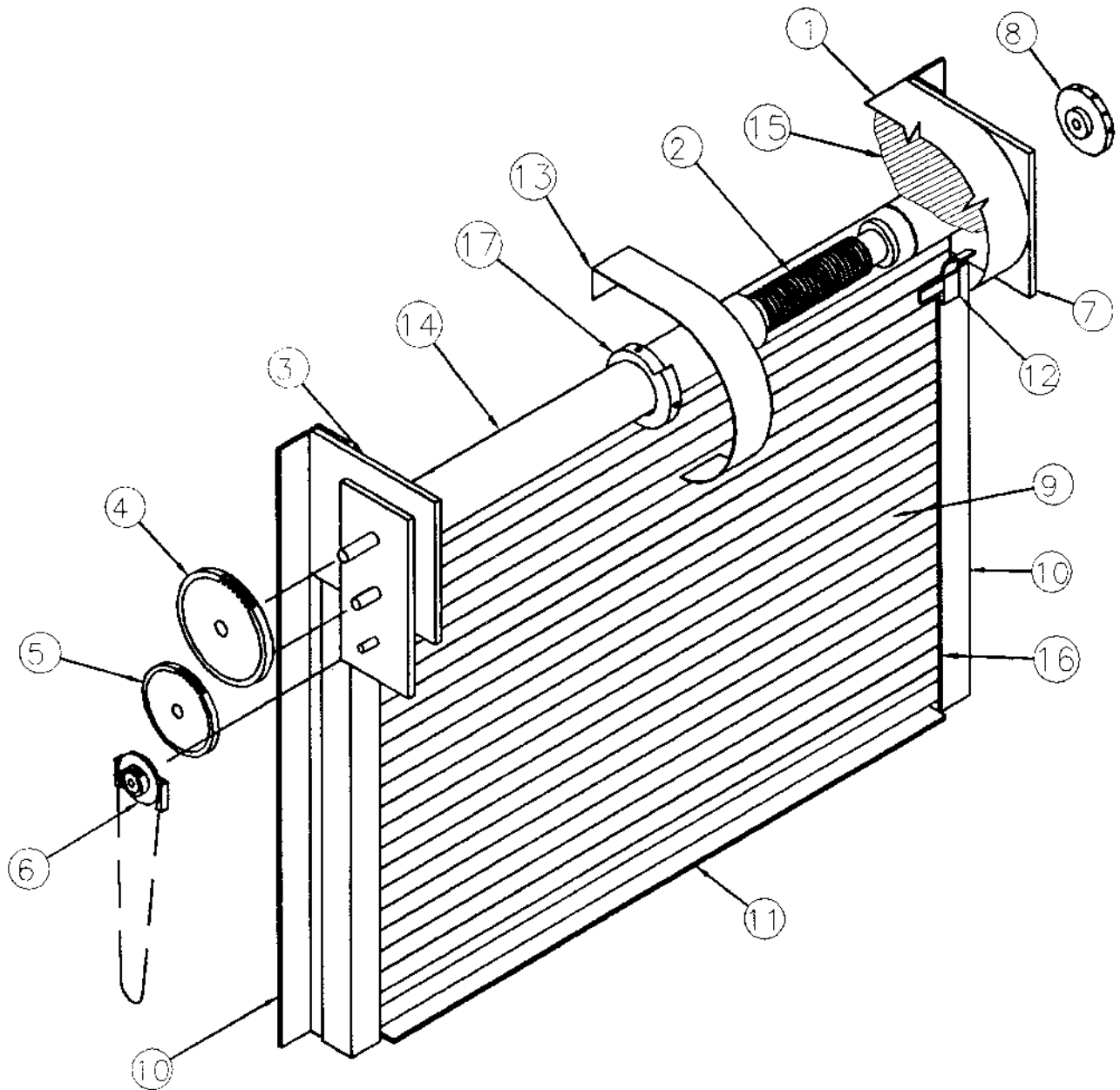

NO.	ITEM
1	Hood
2	Tension Spring
3	Drive Bracket
4	Drive Sprocket
5	Motor Operator*
6	Main Sprocket
7	Tension Bracket
8	Tension Wheel

NO.	ITEM
9	Curtain
10	Guides
11	Bottom Bar
12	Stops
13	Hood Support (where required)
14	Roller Chain
15	Barrel

PARTS LIST:
FACE MOUNTED,
MOTOR OPERATED
SERVICE DOOR

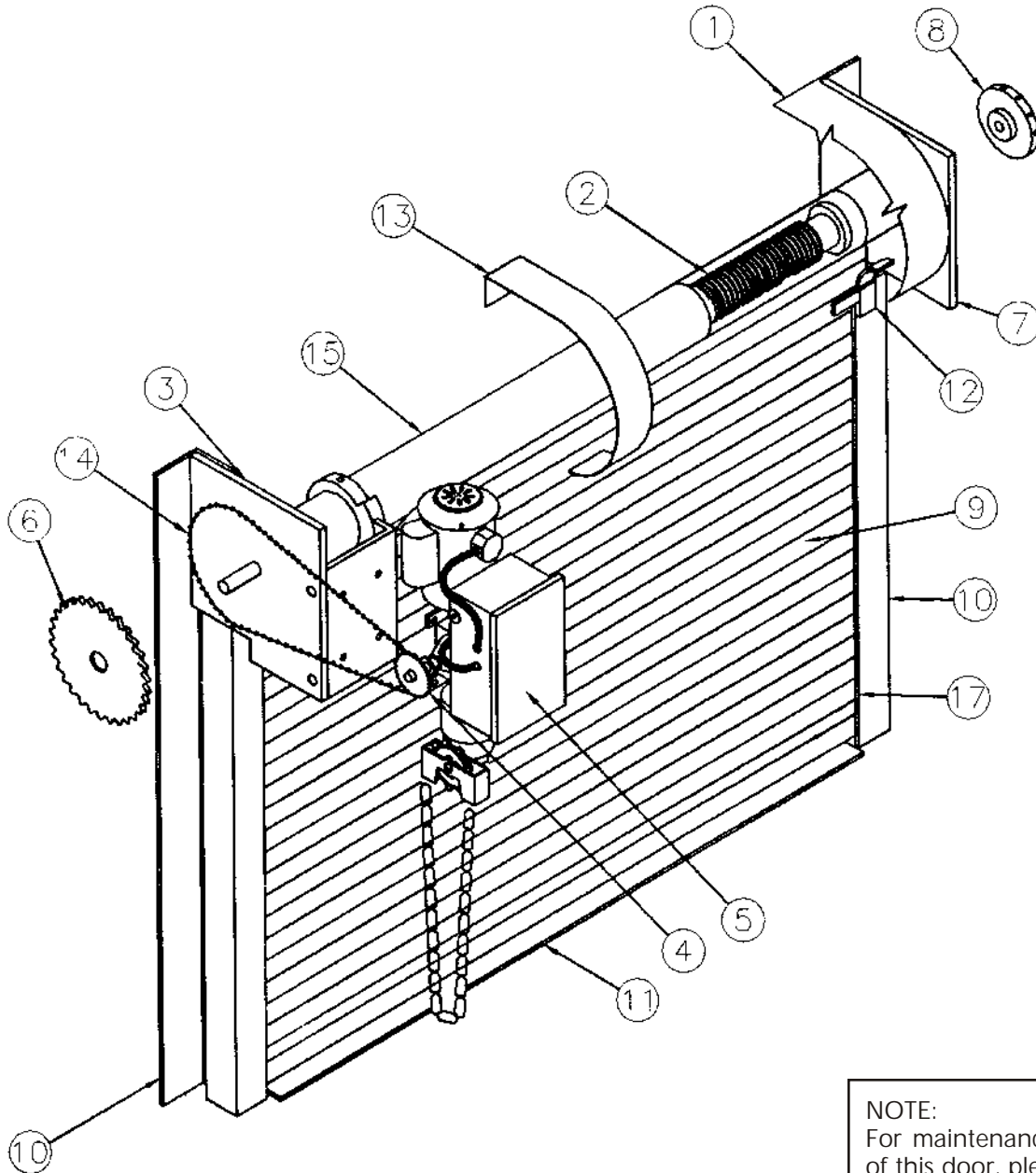

NOTE:
For maintenance or repair
of this door, please consult
your local authorized
Cookson Distributor.

NOTE:
*Configuration of motor operator may be changed as shown due to mounting conditions.

PARTS LIST:
FACE MOUNTED,
MOTOR OPERATED,
INSULATED SERVICE
DOOR

NO.	ITEM
1	Hood
2	Tension Spring
3	Drive Bracket
4	Drive Sprocket
5	Motor Operator*
6	Main Sprocket
7	Tension Bracket
8	Tension Wheel
9	Curtain

NO.	ITEM
10	Guides
11	Bottom Bar
12	Stops
13	Hood Support (where required)
14	Roller Chain
15	Hood Baffle
16	Barrel
17	Weatherstripping
18	Hoops (where required)

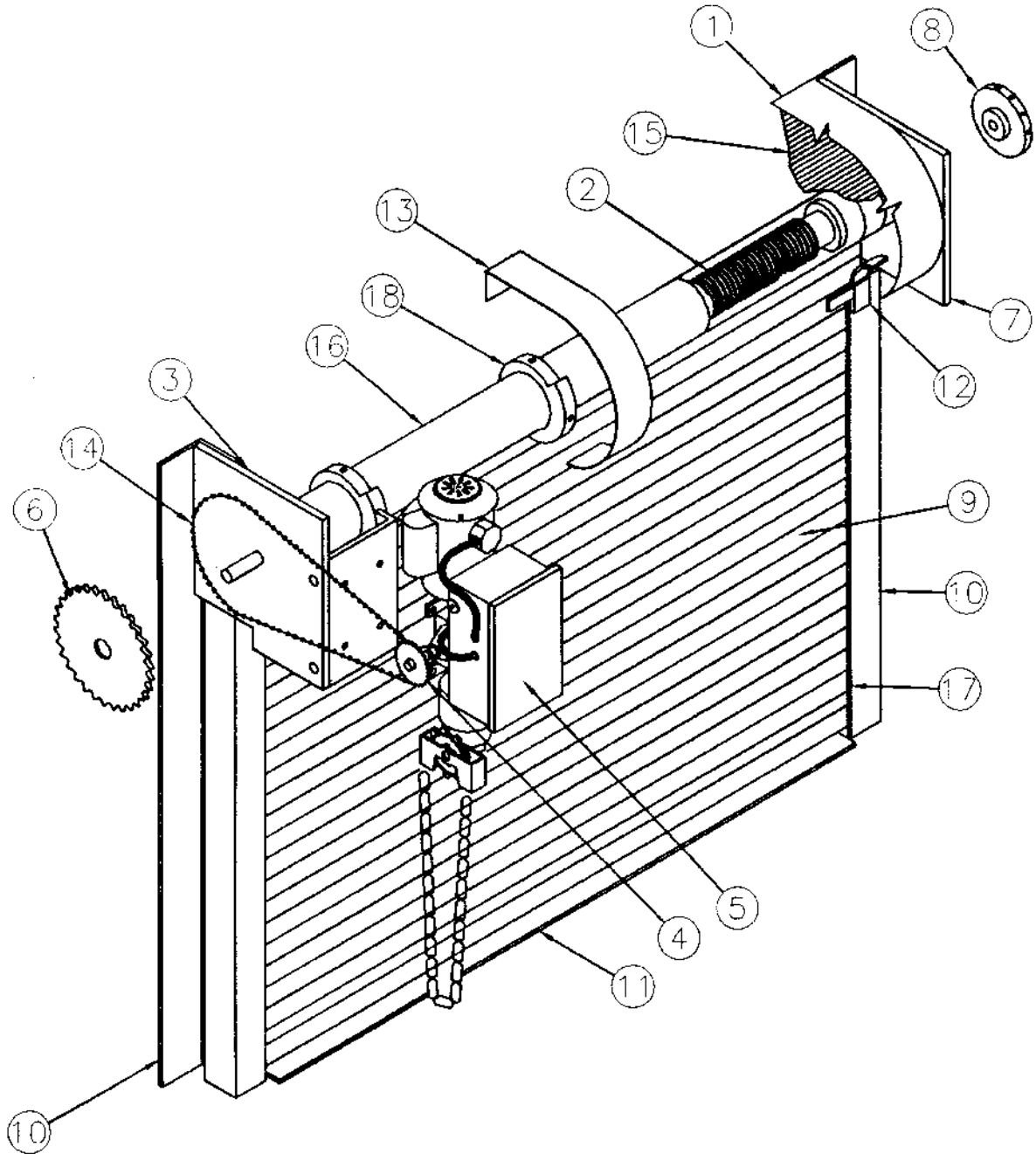

NOTE:
*Configuration of motor operator may be changed as shown due to mounting conditions.

- A. Many problems encountered with rolling doors are a result of improper installation of the door. Each door is provided with a set of installation instructions that must be followed to insure proper operation. Installation problems can remain undetected on doors that are seldom operated, therefore it is important to consider incorrect installation as a common cause of problems.
- B. A door must be inspected prior to installation to insure that none of the components have been damaged in shipment. Damaged components should not be used to install a door.
- C. The guides of the door must be plumb and mounted the correct distance apart along their entire length. Mounting hardware must not project into the guide because the curtain must be free to move in the guide. The tops of guides must be level to insure that the barrel of the door is level. The use of a Hydro-Level is an accurate method of leveling the guides.
- D. The barrel of the door must be free to turn when supported by the brackets. If hoops are required, they must be installed on the barrel before the curtain and brackets are installed on the barrel. The curtain is attached to the barrel with machine screws that pass through slots in the top slat.
- E. The curtain of the door must pass freely through the guides without binding. The guides must be plumb and mounted to the correct guide opening dimension. The guide groove opening must be adjusted to the dimension shown in the installation instructions.
- F. The torsion spring must be tensioned to the number of initial turns shown in the installation instructions. Doors with internal tension wheels are tensioned with door closed. On large motor operated doors, it may not be possible to raise the door by hand if the initial tension is not applied. When this occurs, the weight of the door must be lifted while the hand operator is used to coil the curtain on the barrel.
- G. The door operator must be free to turn and securely mounted to the bracket. Bracket plates must be perpendicular to the barrel to insure that chains, sprockets, and gears engage properly.
- H. All door components are labeled, stamped, or tagged with corresponding Cookson Door Mark. Parts must not be interchanged for different doors.

<p>NOTE: For maintenance or repair of this door, please consult your local authorized Cookson Distributor.</p>
--

BARREL

TROUBLESHOOTING GUIDE		
PROBLEM	CAUSE	CORRECTION
A. Door starts down then binds.	1. Curtain binds in guides.	1. Increase guide groove opening. Curtain must be loose in guides.
	2. Screws connecting curtain to barrel too long and interfering with torsion spring.	2. Replace machine screws with shorter length. They must not protrude past barrel wall.
	3. Incorrect barrel for opening.	3. Check door mark. Locate correct barrel.
	4. Internal interference inside barrel.	4. Consult Distributor.
B. Tension wheel turns freely.	1. Spring broken.	1. Consult Distributor.
	2. Broken shaft tie.	2. Consult Distributor.
	3. Broken barrel tie.	3. Consult Distributor.
C. Tension shaft slipped into barrel.	1. Drive pin failure - shipping damage.	1. Consult Distributor.
	2. Bearing failure - shipping damage.	2. Consult Distributor.
D. Door loses tension.	1. Pawl slipping on internal tension wheel because pawl is binding on attaching rivet.	1. Loosen pawl pivot point.
	2. Door damaged causing increased drag.	2. Consult Distributor.
	3. Hoops slipping.	3. Tighten hoops.
E. Drive shaft crooked.	1. Broken weld or shipping damage.	1. Consult Distributor for determination if field repair is possible.

TROUBLESHOOTING GUIDE		
PROBLEM	CAUSE	CORRECTION
A. Curtain rolls up un-evenly.	<ol style="list-style-type: none"> 1. Top slat not in line. 2. Barrel not level. 	<ol style="list-style-type: none"> 1. Loosen top screws and straighten curtain. 2. Use Hydro-level to level barrel.
B. Door curtain separates.	<ol style="list-style-type: none"> 1. Freight damage. 	<ol style="list-style-type: none"> 1. Consult Distributor.
C. Curtain separates from barrel.	<ol style="list-style-type: none"> 1. Machine screws pulled through top slat. 2. Interlocks not installed on motor operated door. 	<ol style="list-style-type: none"> 1. Install washer under head of screws. 2. Install interlocks to prevent motor operation when door is locked.
D. Finish problems.	<ol style="list-style-type: none"> 1. Stainless steel door corrodes due to environmental conditions. 	<ol style="list-style-type: none"> 1. Clean door periodically with stainless steel wool and rinse with clean water.
E. Curtain appears to sag at center.	<ol style="list-style-type: none"> 1. Center of curtain is against barrel and edge of curtain is pulled toward lintel as it enters guides. 2. Barrel deflection of wide doors. Should not exceed .03 inches per foot of opening width. 	<ol style="list-style-type: none"> 1. Curvature of curtain makes it appear to be sagging while it is actually level. Check with carpenter's level. 2. Consult Distributor.

NOTE:
For maintenance or repair of this door, please consult your local authorized Cookson Distributor.

BOTTOM BAR

TROUBLESHOOTING GUIDE		
PROBLEM	CAUSE	CORRECTION
A. Safety Edge not working.	1. Open circuit in bottom bar. Confirm this by disconnecting plug at bottom bar and inserting continuity checker. If pressing up on safety edge does not close circuit, problem is open circuit in bottom bar.	1. Defective switch or connection at switch to plug. Check to make sure all wires are securely fastened. Replace switch if necessary.
	2. Open circuit in coil cord or cord reel. Confirm this by inserting volt-meter into plug. Reading should be 24V AC.	2. Replace coil cord or cord reel.
	3. Door located in extremely wet or flood environment.	3. Eliminate water. Replace safety edge or safety edge switch.
B. Locks inoperative.	1. Cam of cylinder not in correct position.	1. Reposition cylinder and firmly secure with small screw located below cylinder.
	2. Damage to internal components.	2. Remove bottom bar from guide. Replace lock mechanism.
D. Electrical interlocks inoperative.	1. Lock bolt does not line up with switch on guide.	1. Adjust switch location where it is mounted on guides.
	2. Interlock does not prevent motor from operating.	2. Defective switch, check electrical connection and replace if necessary.

TROUBLESHOOTING GUIDE		
PROBLEM	CAUSE	CORRECTION
A. Brackets not perpendicular to barrel.	1. Wall angle flange not square.	1. Brace bracket into position.
B. Drive chain tension.	1. Sprocket position out of adjustment.	1. Tighten chain by sliding operator or remove link from chain.
C. Binding in bevel gear box.	1. Lack of lubrication.	1. Lubricate gear box.

BRACKET

TROUBLESHOOTING GUIDE		
PROBLEM	CAUSE	CORRECTION
A. Curtain binds in guide groove.	1. Incorrect guide groove opening.	1. Refer to installation instructions and adjust guide groove opening.
	2. Incorrect tip to tip dimension of guides.	2. Refer to installation instructions for tip to tip dimension and adjust guide spacing.

GUIDE

TROUBLESHOOTING GUIDE		
PROBLEM	CAUSE	CORRECTION
A. Incorrect dimensions, material, or end covers.	1. Ordering processing problem.	1. Get all dimensions of material supplied and consult distributor.

HOOD

NOTE:
For maintenance or repair of this door, please consult your local authorized Cookson Distributor.

MOTOR OPERATOR

TROUBLESHOOTING GUIDE		
PROBLEM	CAUSE	CORRECTION
A. Emergency hand chain or crank fails or is difficult to operate door.	<ol style="list-style-type: none"> 1. Door may be jammed or obstructed. 2. Incorrect tension in spring. 3. Door may be locked. 4. Problem in gearbox housing. 	<ol style="list-style-type: none"> 1. Remove Obstruction. 2. Make sure that spring has correct tension. 3. Check to see if lock is disengaged. 4. Consult Distributor.
B. Emergency hand chain or crank turns but does not turn the output shaft of gear box.	<ol style="list-style-type: none"> 1. Keys fixing gears to shafts are sheared. 	<ol style="list-style-type: none"> 1. Check keys and keyways.
C. Motor fails to run or control circuit fails to energize.	<ol style="list-style-type: none"> 1. Fuses blown or circuit breaker "tripped". 2. Operators are protected from running in overload condition by thermal overload devices of the automatic reset type. 3. If contacts for motor controller energize but motor still fails to operate. 4. Pushbuttons energize on only one side of the control contacts. 	<ol style="list-style-type: none"> 1. Check fuse or circuit breaker box. 2. Consult Distributor. 3. Consult Distributor. 4. Check all electrical connections for broken or loose wires, etc. Check electrical connections for any optional equipment: Card Key, Cylinder Key Switch, Photo Cell, Reversing Bottom Bar or Special Interlocks.
D. Movement of the door is in agreement with pushbutton station, but the limit switch does not stop the door.	<ol style="list-style-type: none"> 1. Electrical connections are switched. 	<ol style="list-style-type: none"> 1. Check electrical connections and jumper wire lead between the micro switches. Consult Distributor.
E. Limit Switch does not hold its setting.	<ol style="list-style-type: none"> 1. Sprocket shaft end play too large. 2. Drive chain loose. 3. Limit switch detent plate loose. 	<ol style="list-style-type: none"> 1. End play should not exceed $\frac{1}{32}$". 2. Check drive chain. 3. The plate must engage both traveling cams.

MOTOR OPERATOR
(continued)

TROUBLESHOOTING GUIDE		
PROBLEM	CAUSE	CORRECTION
F. Electrical Control Circuit energizes but the motor does not run or motor overloads trip.	1. Incorrect wiring.	1. Consult Distributor.
G. Low voltage to motor.	1. Incorrect electrical power to motor.	1. Check voltage against the correct voltage stamped on the motor. If the voltage is 10% below the rating, there is not sufficient voltage to run the motor.
H. Motor is burned out.	1. Incorrect wiring.	1. Consult Distributor.

NOTE:
For maintenance or repair of this door, please consult your local authorized Cookson Distributor.

PARTS LIST:
VERTICAL MOUNTED
MOTOR

NO.	ITEM
1	Motor and Controller
2	Manual Chain Operator
3	Drive Sprocket
4	Main Sprocket
5	Bracket Plate

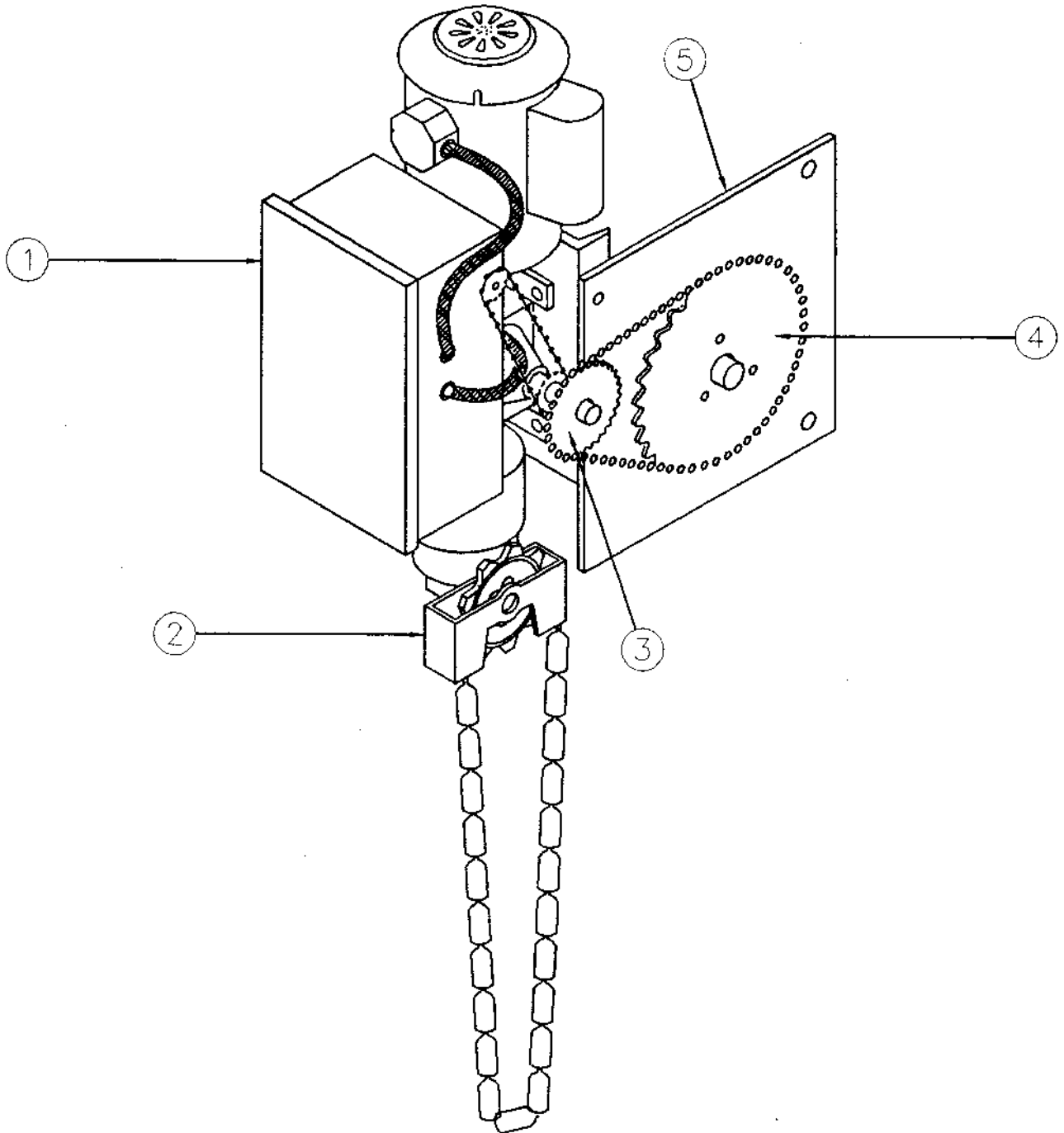

NO.	ITEM
1	Motor and Controller
2	Manual Chain Operator
3	Bracket Plate
4	Drive Sprocket
5	Main Sprocket

PARTS LIST:
HORIZONTAL
MOUNTED MOTOR

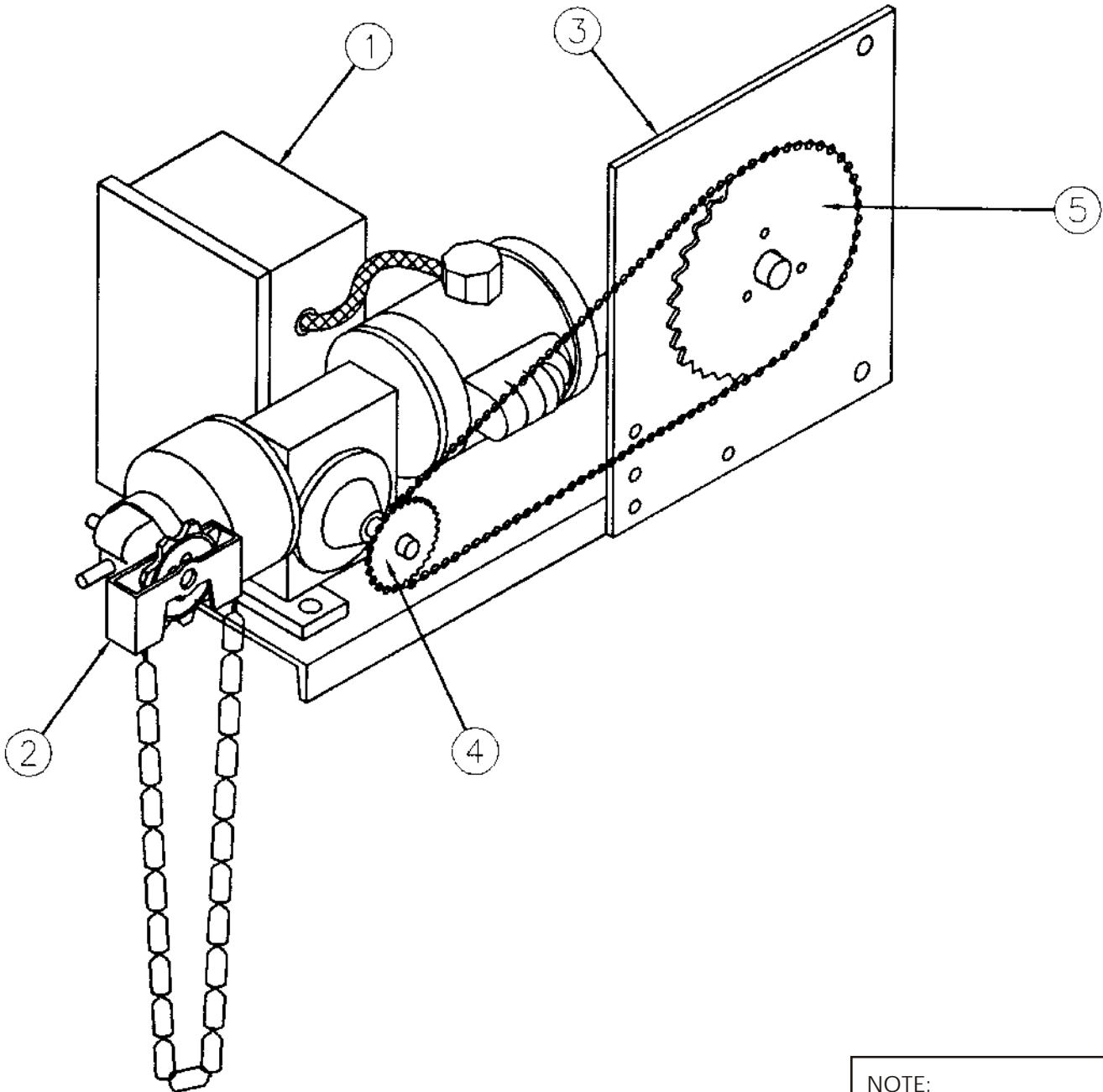

NOTE:
For maintenance or repair
of this door, please consult
your local authorized
Cookson Distributor.

PARTS LIST:
SIDE MOUNTED
MOTOR

NO.	ITEM
1	Motor Operator
2	Bracket Plate
3	Main Sprocket
4	Manual Operator

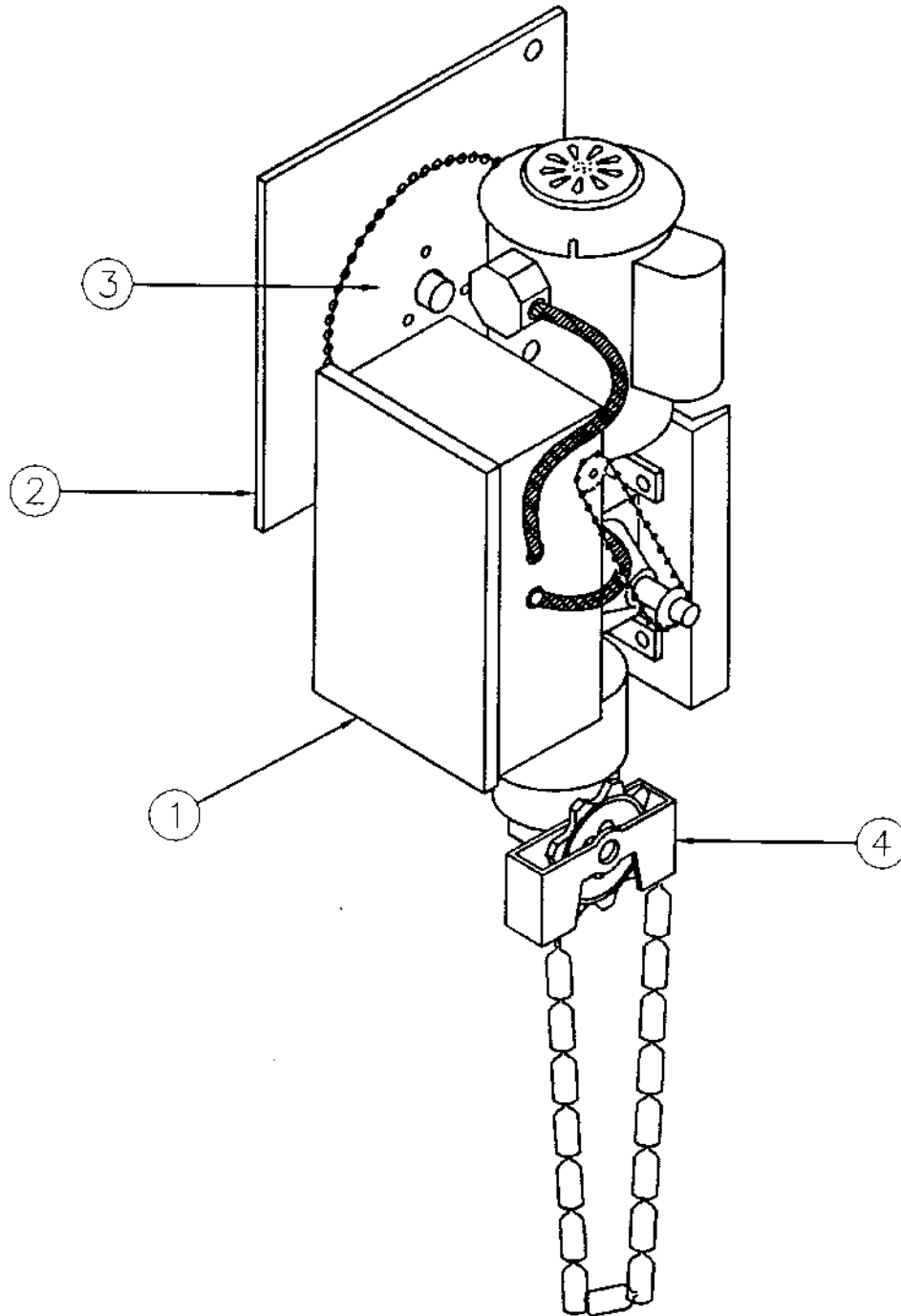

NO.	ITEM
1	Motor
2	Limit Switch Main Sprocket
3	Control Panel
4	Drive Sprocket
5	Miter Gear
6	Release Linkage
7	Chain Sprocket

NO.	ITEM
8	Chain Guard
9	Gear Box
10	Manual Operator Lever
11	Roller Chain
12	Limit Switch Drive Sprocket
13	Reducer

PARTS LIST:
MODEL GH
MOTOR

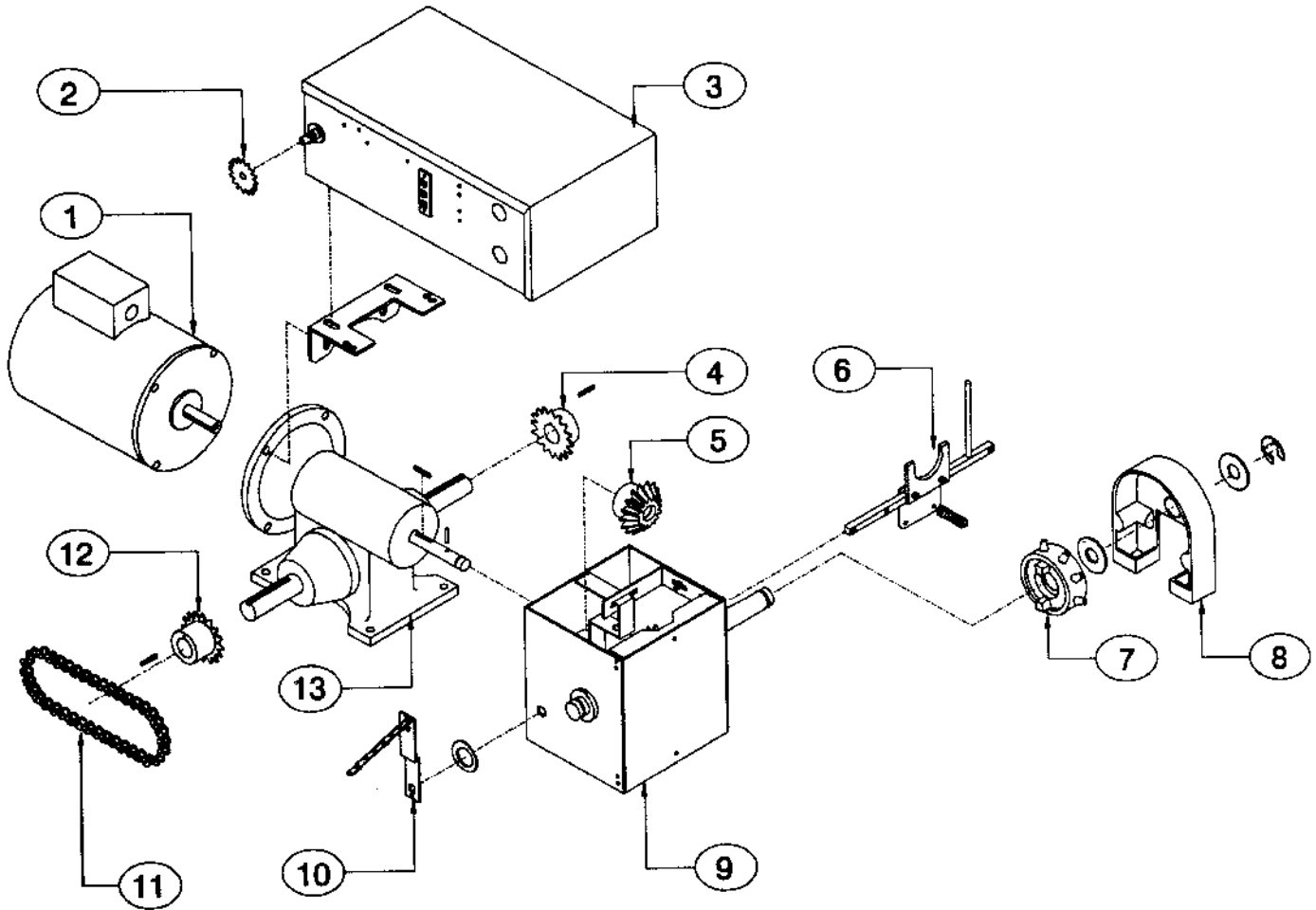

NOTE:
For maintenance or repair
of this door, please consult
your local authorized
Cookson Distributor.

PARTS LIST:
MODEL MH MOTOR

NO.	ITEM
1	Control Panel
2	Limit Switch Main Sprocket
3	Roller Chain
4	Limit Switch Drive Sprocket
5	Release Linkage
6	Chain Guard
7	Chain Sprocket

NO.	ITEM
8	Manual Operator Lever
9	Motor
10	Gear Box Enclosure
11	Drive Pulley
12	Main Pulley
13	Drive Belt
14	Drive Sprocket

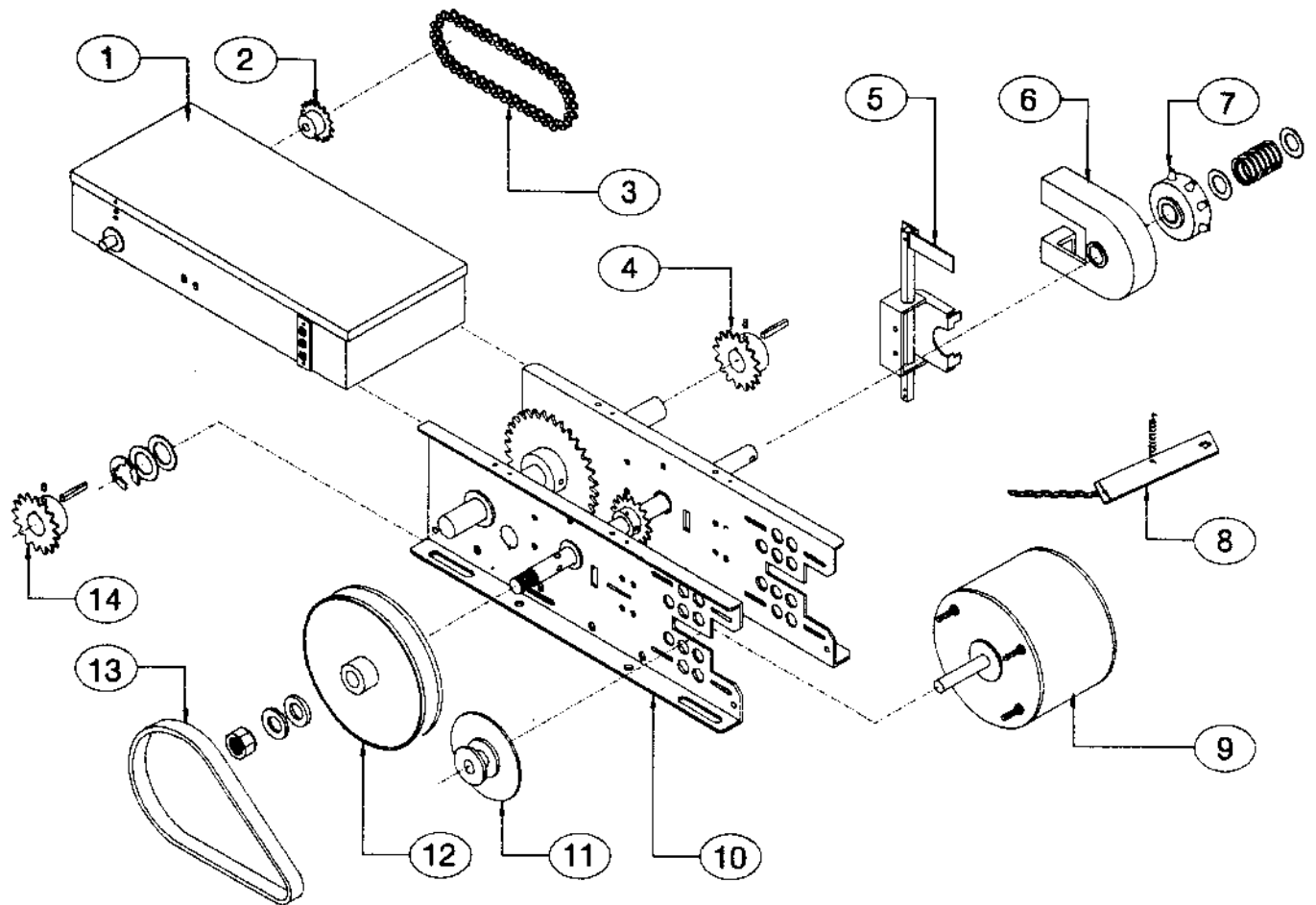

NO.	ITEM
1	Manual Operator Lever
2	Limit Switch Drive Sprocket
3	Gear Box Enclosure
4	Drive Sprocket
5	Main Pulley
6	Control Panel
7	Drive Belt

NO.	ITEM
8	Drive Pulley
9	Motor
10	Limit Switch Main Sprocket
11	Roller Chain
12	Release Linkage
13	Chain Guard
14	Chain Sprocket

PARTS LIST:
MODEL H
MOTORS

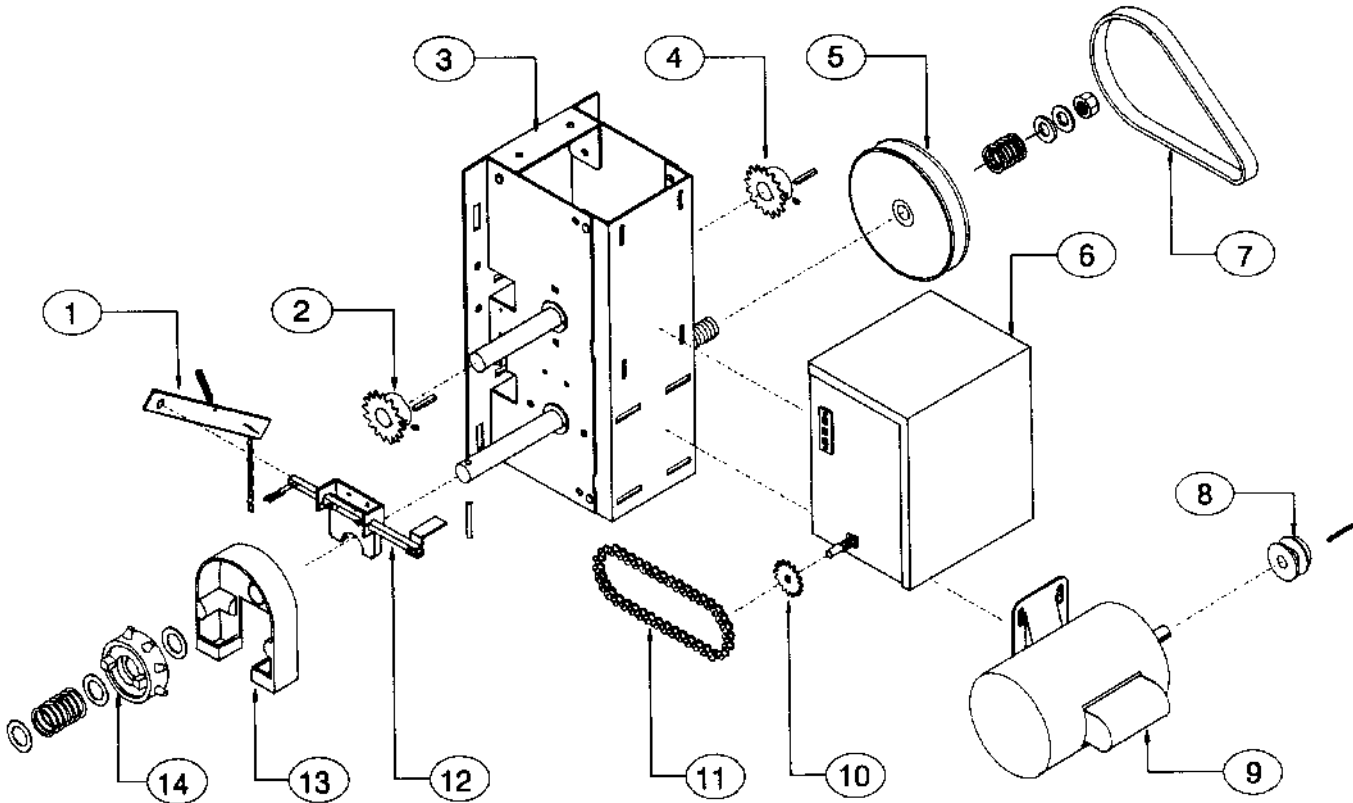

NOTE:
For maintenance or repair
of this door, please consult
your local authorized
Cookson Distributor.

PARTS LIST:
MODEL GJ MOTOR

NO.	ITEM
1	Reducer
2	Motor
3	Motor Mounting Bracket
4	Release Cam
5	Drive Sprocket
6	Release Linkage
7	Manual Operator Lever
8	Roller Chain
9	Control Panel
10	Limit Switch Drive Sprocket

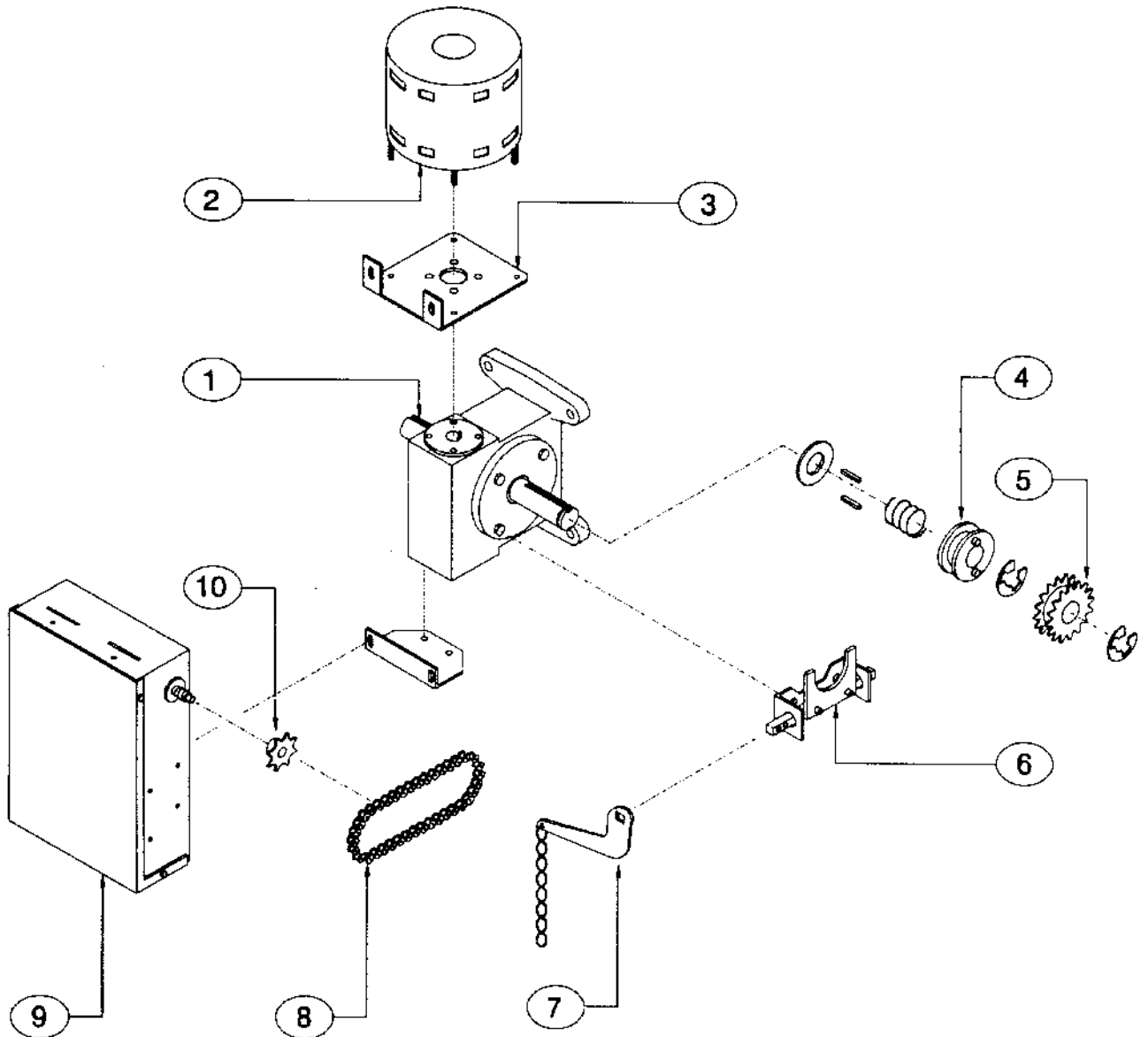

Push-Up

Be sure the rolling door is unlocked, grip the center of the bottom bar and smoothly lift in an upward motion. To close, gently pull the bottom bar down taking caution not to let the door fall.

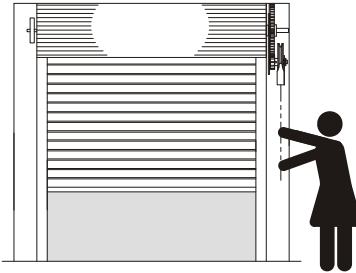
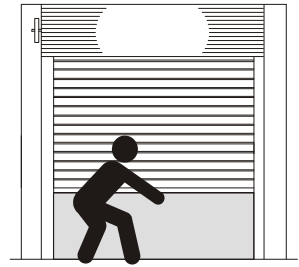

Chain

Pull the outermost part of the chain loop (farthest away from the door) vertically downward to open. To close, pull the innermost part of the chain loop (closest to the door) vertically downward. Do not let the door fall; always chain it down, maintaining control of the chain. Use both hands to govern the descent of the door.

Crank

Insert tip of winding shaft into the hook located on the drive bracket. Holding the lower piece of the crank rod secure with one hand, crank the middle piece clockwise with the other hand. Reverse this action to close the door.

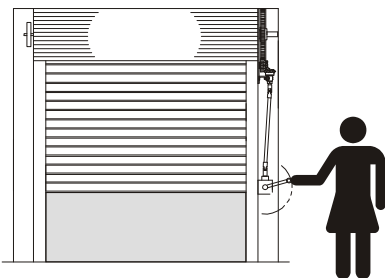
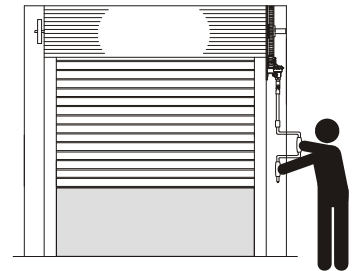

Crank Box

With a secure grip on the handle, crank the handle in a clockwise direction to open the door. Crank counterclockwise to close the door.

Motor

Press the open button to open the door, press the stop button to stop the movement of the door, and press the close button to close the door.

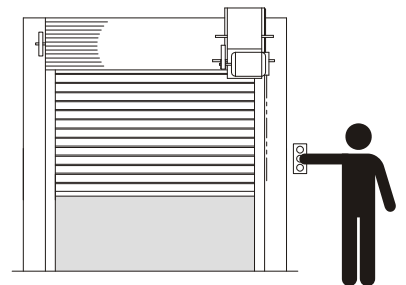

WARNING: When operating a rolling door always make sure there are no obstructions blocking the path of movement. Keep feet and other limbs away from the door while it is in motion. When opening a pushup operated door, use caution to lift with your legs and not your back. The Cookson Company and affiliates shall not be held responsible for injury or damage due to failure to follow operating instructions.

Annual Inspection of Door

All rolling doors should be inspected annually by an Authorized Cookson Distributor. For the location of the nearest dealer please call (800)390-8590 or visit our web site at cooksondoor.com and look under Contacts.

**MAINTENANCE
INSTRUCTIONS**
Caution: Only trained
personnel should
perform maintenance

Regular Scheduled Maintenance

All rolling doors should be inspected on a regular basis to ensure proper and safe operation. The frequency of the inspection is dependent on the usage of the door but all doors should be inspected at least once a month. The inspection should consist of the following:

- A. Visual Inspection
 - 1. Bent Bottom Bars
 - 2. Damaged slats
 - 3. Pinched guides
 - 4. Dented or missing hood
- B. Check All Fasteners
 - 1. Wall attachment bolts
 - 2. Guide assembly bolts
 - 3. Bracket attachment bolts
 - 4. Set screws on gears and sprockets
 - 5. Tension wheel secure
 - 6. Keys secure
- C. Check Operating Assemblies
 - 1. Operating Assembly
 - 2. Barrel Assembly
- D. Lubricate
 - 1. All Pivot Joints
 - 2. Shafts
 - 3. Roller Chain
- E. Check Normal Operation
 - 1. Operation
 - 2. Spring Tension
 - 3. Balance

If any parts of the rolling door are damaged they should be replaced immediately. All Cookson Rolling Doors should be repaired with Cookson Rolling Door parts. The use of other parts will void all warranties and may result in unsafe operation.

<p>NOTE: For maintenance or repair of this door, please consult your local authorized Cookson Distributor.</p>
--

